

# Unical®

## *ALKON*

**18 R**

**24 R - 24 C**

**28 R - 28 C**

**35 R - 35 C**

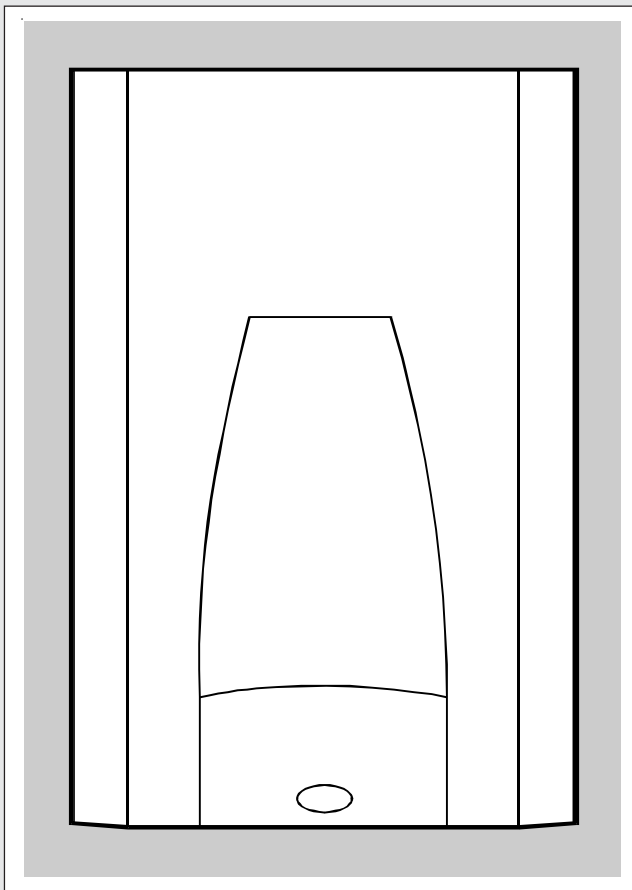

## **INSTALLATION AND SERVICING MANUAL**

00332495 -4<sup>th</sup> edition - 02/2009

English

**Warning: this manual contains instructions to be used exclusively by the installer and/or a competent person in accordance with the current laws in force.**

**The end user MUST not make any alterations to the boiler.**

**Failure to follow the instructions indicated in this manual, which is supplied with the boiler, could cause injury to persons, animals or damage to property.**

**UNICAL shall not be held liable for any injury and/or damage.**

## CONTENTS

<b>1 GENERAL INFORMATION .....</b>	<b>3</b>
1.1 Symbols used in this manual .....	3
1.2 Correct use of the appliance .....	3
1.3 Water treatment .....	3
1.4 Information to be handed over to the user .....	3
1.5 Safety warnings .....	4
1.6 Data badge .....	5
1.7 General warnings .....	6
<b>2 TECHNICAL FEATURES AND DIMENSIONS .....</b>	<b>7</b>
2.1 Technical features .....	7
2.2 Dimensions .....	7
2.3 Main components .....	8
2.4 Boiler water circuit .....	9
2.5 Performance data according to the Standard UNI 10348 .....	10
2.6 General features .....	10
<b>3 INSTRUCTIONS FOR THE INSTALLER .....</b>	<b>11</b>
3.1 General warnings .....	11
3.2 Standard codes for installation .....	12
3.3 Packaging .....	12
3.4 Boiler location .....	13
Dimensions for connecting the Alkon 28 to the external storage tank kit DSP120 .....	14
3.5 Boiler installation .....	16
3.6 Gas connection .....	16
3.7 Central heating connections .....	17
3.8 DHW connections .....	19
3.9 Examples of system pipework connections .....	20
3.10 Condensate drain .....	21
3.11 Flue outlet installation .....	22
3.12 Electrical connections .....	22
General warnings .....	28
Connection to mains supply 230V .....	28
Access to the terminal block and external connections .....	28
Outdoor sensor connection .....	29
ON-OFF digital room controller connection .....	30
Modulating RT/OT room controller connection .....	30
Layout of the electrical connection for zone control systems .....	31
3.13 Wiring diagrams .....	32
Functional flow wiring diagram for Alkon 24/28/35 C .....	32
Functional flow wiring diagram for Alkon 18/24/28/35 R .....	33
Jumper installation on the modulating board .....	34
3.14 Filling the system .....	35
3.15 Initial lighting .....	36
3.16 Burner pressure adjustment .....	37
3.17 Variation of output range .....	40
<b>4 SERVICING SCHEDULE .....</b>	<b>42</b>
Instructions for inspecting and servicing the appliance .....	42
<b>5 FAULT CODES .....</b>	<b>45</b>
<b>6 CE CERTIFICATE .....</b>	<b>47</b>

1

# GENERAL INFORMATION

## 1.1 - SYMBOLS USED IN THIS MANUAL

When reading this manual particular care has to be given to the parts marked with the followings symbols:



**DANGER!** Indicates serious danger for your personal safety and for your life



**WARNING!** Indicates a potentially dangerous situation for the product and the environment



**NOTE!** Suggestions for the user

## 1.2 - A CORRECT USE OF THE APPLIANCE



The ALKON appliance has been designed utilizing today's heating technology and in compliance with the current safety regulations.

However, following an improper use, dangers could arise for the safety and life of the user or of other people, or damage could be caused to the appliance or other objects.

The appliance is designed to be used in pumped hot water central heating systems and for the production of domestic hot water.

Any other use of this appliance will be considered improper.

**UNICAL declines any responsibility for any damages or injuries caused by an improper use; in this case the risk is completely at the user's responsibility.**

In order to use the appliance according to the foreseen scopes it is necessary to carefully follow the instructions indicated in this manual.

## 1.3 - WATER TREATMENT



- The hardness of the mains water supply conditions the frequency with which the DHW heat exchanger is cleaned.
- In hard water areas where the main water can exceed 15°f total hardness, a scale reducing device is recommended. The choice of this device has to be made taking into consideration the characteristics of the water.
- In order to improve the resistance to lime scale it is recommended to adjust the domestic hot water temperature as near as possible to the one you really require.
- We recommend you to check the state of cleanliness of the domestic hot water heat exchanger at the end of the first year and subsequently, on the basis of the lime scale found, this period can be extended to two years.

## 1.4 - INFORMATION TO BE HANDED OVER TO THE USER



The user has to be instructed on the use and operation of his heating system, in particular:

- Hand over these instructions to the end user, together with any other literature regarding this appliance placed inside the envelope contained in the packaging. **The user has to keep these documents in a safe place in order to always have them at hand for future reference.**
- Inform the user on the importance of air vents and of the flue outlet system, stressing the fact that is absolutely forbidden to make any alterations to the boiler.
- Inform the user how to check the system's water pressure as well as informing him how to restore the correct pressure.
- Explain the function of time and temperature controls, thermostats, heating controls and radiators, to ensure the greatest possible fuel economy.
- Remind the user that, in order to comply to the standards in force, it is necessary to inspect and service the boiler according to the current codes of practice and according to the schedule indicated in this manual by the manufacturer.
- If the appliance is sold or transferred to another owner or if the present user moves home and leaves the appliance installed, ensure yourself that the manual always follows the appliance so that it can be consulted by the new owner and/or installer.

**Failure to follow the instructions indicated in this guide, which is supplied with the boiler, could cause injury to persons, animals or damage to property. The manufacturer shall not be held liable for any such injury and/or damage.**

## General information

### 1.5 - SAFETY WARNING



#### **WARNING!**

The installation, adjustment, and servicing of this appliance must be carried out by a competent person and installed in accordance with the current standards and regulations. Failure to correctly install this appliance could cause injury to persons, animals or damage to property. The manufacturer shall not be held liable for any injury and/or damage.



#### **DANGER!**

Servicing or repairs of the appliance must be carried out by UNICAL authorised service technicians; UNICAL recommends drawing up a service contract. Bad or irregular servicing could compromise the safe operation of the appliance, and could cause injury to persons, animals or damage to property for which UNICAL shall not be held liable.



#### **Alterations to parts connected to the appliance**

Do not carry out any alterations to the following parts:

- the boiler
- to the gas, air, water supply pipes and electrical supply
- to the flue pipe, safety relief valve and its drainage pipe
- to the constructive components which influence the appliance's safe operation



#### **WARNING!**

When tightening or loosening the screw pipe connections, use only adequate fork spanners. The improper use and/or the use of inadequate equipment can cause damages (for example water or gas leakages).



#### **WARNING!**

Indications for appliances operating with propane gas

Ensure yourself that before installing the appliance the gas tank has been purged.

For a correct purging of the tank contact the liquid gas supplier or a competent person who has been legally authorized.

If the tank has not been correctly purged problems could occur during ignition.

If this occurs contact the liquid gas tank's supplier.



#### **Smell of gas**

If you smell gas follow these safety indications:

- Do not turn on or off electrical switches
- Do not smoke
- Do not use the telephone
- Close the mains gas tap
- Open all windows and doors where the gas leakage has occurred
- Contact the gas society or a company specialized in installing and servicing heating systems



#### **Explosive and easily inflammable substances**

Do not use or leave explosive or easily inflammable material (as for example: petrol, paint, paper) in the room where the appliance has been installed.

## 1.6 - DATA BADGE

### CE Marking

- The CE marking documents that the boilers satisfy:
- The essential requirements of the Directive regarding gas appliances (Directive 90/396/CEE)

- The essential requirements of the Directive regarding electromagnetic compatibility (Directive 89/336/CEE)
- The essential requirements of the Efficiency Directive (Directive 92/42/CEE)
- The essential requirements of the low voltage Directive (Directive 73/23/CEE)

### LEGEND:

- |   |  |
|---|--|
| 1 = CE Surveillance notify body                                     | 17 = (R factor) N° taps based on the quantity of water declared EN 13203-1 |
| 2 = Boiler type   | 18 = (F factor) N° stars based on the quality of water declared EN 13203-1 |
| 3 = Boiler model  | 19 = (PMW) Max. pressure D.H.W. system                                     |
| 4 = Number of stars (Directive 92/42/CEE)                           | 20 = (T max) Max. temperature D.H.W. system                                |
| 5 = (S.N°) Serial number  |  |
| 6 = P.I.N. code   |  |
| 7 = Approved fluing configurations                                  |  |
| 8 = (NOx) NOx class   |  |
|   | <b>C = Electrical features</b>   |
| <b>A = Central Heating circuit features</b>                         | 21 = Electrical power supply   |
| 9 = (Pn) Nominal output   | 22 = Consumption   |
| 10 = (Pcond) Condensing nominal output                              | 23 = Protection grade  |
| 11 = (Qmax) Nominal heat input                                      |  |
| 12 = (Adjusted Qn) Adjusted for nominal Heat input                  | <b>D = Countries of destination</b>  |
| 13 = (PMS) Max. pressure C.H. system                                | 24 = Direct and indirect country of destination                            |
| 14 = (T max) Max. C.H. temperature                                  | 25 = Gas family  |
|   | 26 = Supply pressure   |
| <b>B = Domestic Hot Water circuit features</b>                      | <b>E = Factory setting</b>   |
| 15 = (Qnw) Nominal heat input in D.H.W. mode (if different from Qn) | 27 = Adjusted for gas type X   |
| 16 = (D) Specific D.H.W. flow rate according to EN 625 - EN 13203-1 | 28 = Space for national brands   |

## General information

### 1.7 - GENERAL WARNINGS

This instruction manual is an integral and indispensable part of the product and must be retained by the user.

Please read carefully the instructions contained in this manual as they provide important indications regarding the safe installation, use and servicing of this appliance.

Keep this manual in a safe place for future reference.

The installation and servicing must be carried out in accordance with the regulations in force according to the manufacturer's instructions and by legally competent authorized persons.

By a competent person, we imply a person who has a specific technical qualification in the field of components for central heating systems for domestic use, domestic hot water production and servicing. The person must have the qualifications foreseen by the current laws in force.

Bad or irregular servicing could compromise the safe operation of the appliance, and could cause injury to persons, animals or damage to property. The manufacturer shall not be held liable for any such injury and/or damage.

Before carrying out any cleaning or servicing turn off the electrical supply to the boiler by means of the ON/OFF switch and/or by means of the appropriate shutdown devices.

Do not obstruct the inlet/outlet terminals.

In the event of failure and/or faulty functioning of the appliance, switch off the boiler. Do not attempt to make any repairs: contact qualified technicians.

Any repairs must be carried out solely by Unical authorized technicians and using only original spare parts. Non-observance of the above requirement may jeopardize the safety of the appliance.

To guarantee the efficiency and correct functioning of the appliance it is indispensable to have the boiler serviced annually by a qualified person.

If the boiler remains unused for long periods, ensure that any dangerous parts are rendered innocuous.

If the appliance is sold or transferred to another owner or if the present user moves home and leaves the appliance installed, ensure yourself that the manual always follows the appliance so that it can be consulted by the new owner and/or installer.

Only original accessories must be used for all appliances supplied with optional extras or kits (including electrical ones).

This appliance must be used only for the purposes for which it has been expressly designed. Any other use shall be considered incorrect and therefore dangerous.

# 2

## TECHNICAL FEATURES AND DIMENSIONS

The **ALKON** boiler is a thermal gas fired unit with an atmospheric fully pre-mixed burner.

These boilers are designed for use on the 2<sup>nd</sup> family gas category II<sub>2H3P</sub>.

Range of models available:

### ONLY CENTRAL HEATING PRODUCTION

ALKON 18 R with an output of 18 kW

ALKON 24 R with an output of 24 kW

ALKON 28 R with an output of 28 kW

ALKON 35 R with an output of 35 kW

### CENTRAL HEATING + DOMESTIC HOT WATER PRODUCTION

ALKON 24 C with an output of 24 kW

ALKON 28 C with an output of 28 kW

ALKON 35 C with an output of 35 kW

The ALKON boilers are supplied complete with all the safety and control devices in accordance with all the current regulations. Their technical and functional features comply with the regulations prescribed by the law No. 1083 dated 06/12/1971, concerning safety and use of combustible gas and with the requirements prescribed in the law No. 10 dated 09/01/1991 and any subsequent amendments – Gas Directive 90/396 CEE – Efficiency Directive 92/42 CEE – Electromagnetic Compatibility Directive 89/336 CEE – Low Voltage Directive 73/23 CEE.

Moreover, the boilers of the **ALKON** range are classified as “CONDENSING BOILERS” according to the Directive 92/42 CEE appendix 2 (4 stars) and appendix 6 (D.M 660).

### DESCRIPTION OF COMPONENTS AND FEATURES

- Aluminium heat exchanger/condenser;
- Electronic ignition;
- Flame modulation in function of the absorbed power;
- Minimum heat output adjustment in CH mode;
- Electronic adjustment of the ignition ramp;
- Electronic frost protection mode;
- Pump overrun function;
- Safety high limit thermostat;
- Flow temperature sensor;
- Return temperature sensor;
- DHW temperature sensor (only on the ALKON C model);
- Three speed circulating pump with air vent;
- Expansion vessel;
- Automatic air vent;
- Low water pressure switch;
- Control panel with electrical protection IP X4D;
- Temperature water gauge;
- Illuminating led indicator for: power On, CH demand, burner ON, boiler lock-out, fault code display;
- DHW temperature selector switch:35/60°C (only for the ALKON C model);
- CH temperature selector switch + summer/winter position;
- Reset/Chimneysweeper switch
- Rapid DHW delivery switch RIRA ((only for the ALKON C model);
- Steel wall mounting template for system pipework connections.

## 2.2 - DIMENSIONS

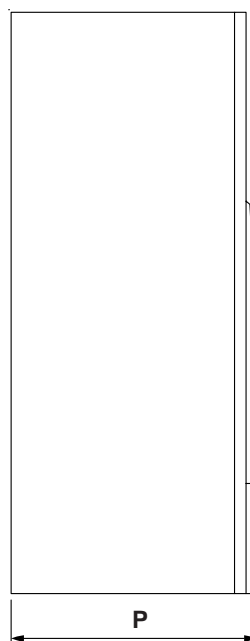
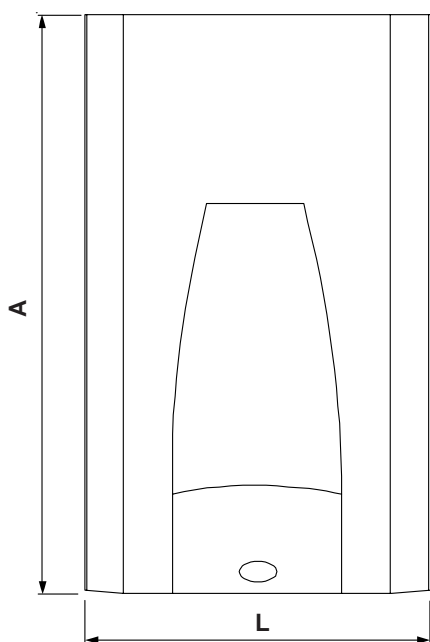

	ALKON		
	18	24/28	35
A	700	750	750
L	350	398	448
P	325,5	325,5	325,5

## Technical features and dimensions

### 2.3 - MAIN COMPONENTS

ALKON R

ALKON C

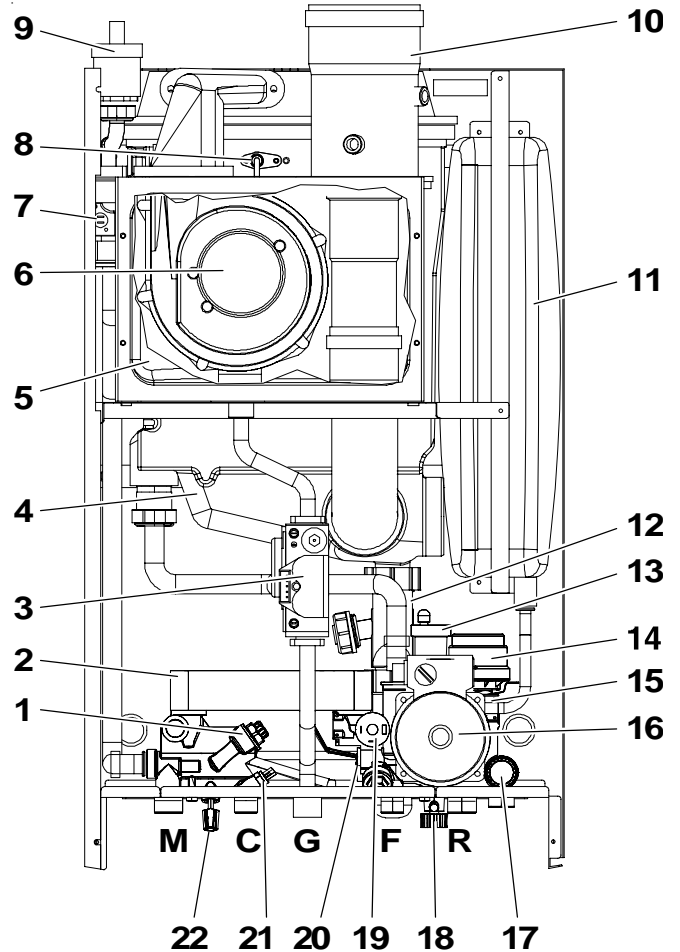
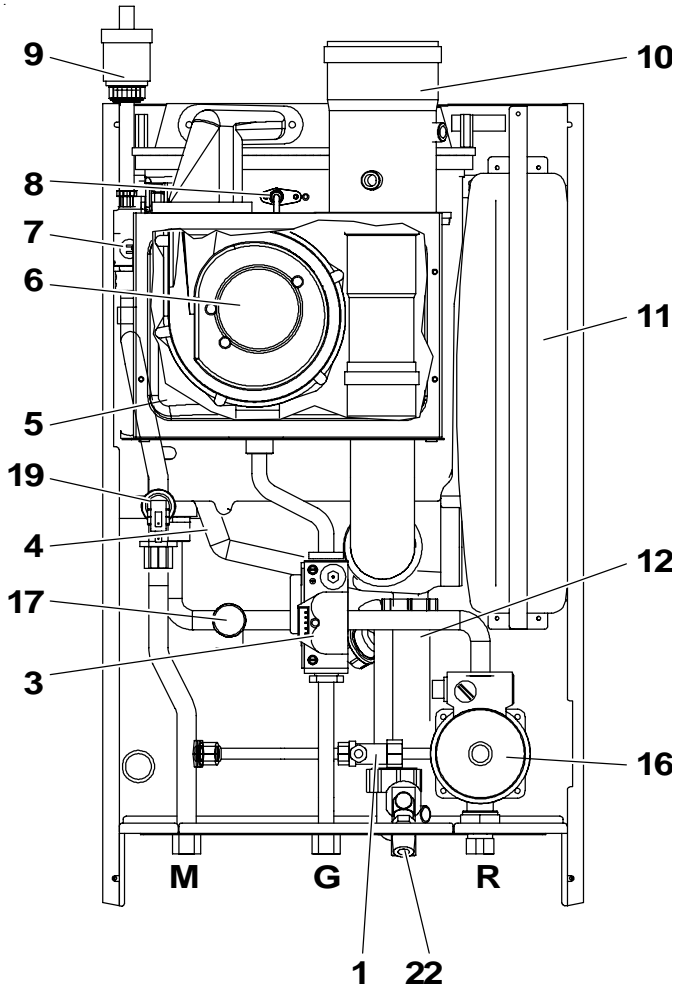

1. By-pass
2. Plate heat exchanger
3. Gas valve
4. Aluminium heat exchanger/condenser
5. Sealed chamber
6. Fan
7. Overheat safety thermostat
8. Ignition and flame detection electrode
9. Air vent valve
10. Flue outlet/combustion air inlet
11. Expansion vessel
12. Condensate drain siphon
13. Automatic air vent
14. Diverter valve motor

15. Diverter valve
16. Pump
17. Central heating circuit safety valve
18. System drain cock
19. Low water pressure switch
20. Flow switch
21. Domestic hot water temperature sensor
22. Filling system cock

- M C.H system flow (3/4")  
 C DHW outlet (1/2")  
 G Gas inlet (3/4")  
 F Cold water inlet (1/2")  
 R C.H. system return (3/4")



## 2.4 - BOILER WATER CIRCUITS

### ALKON R

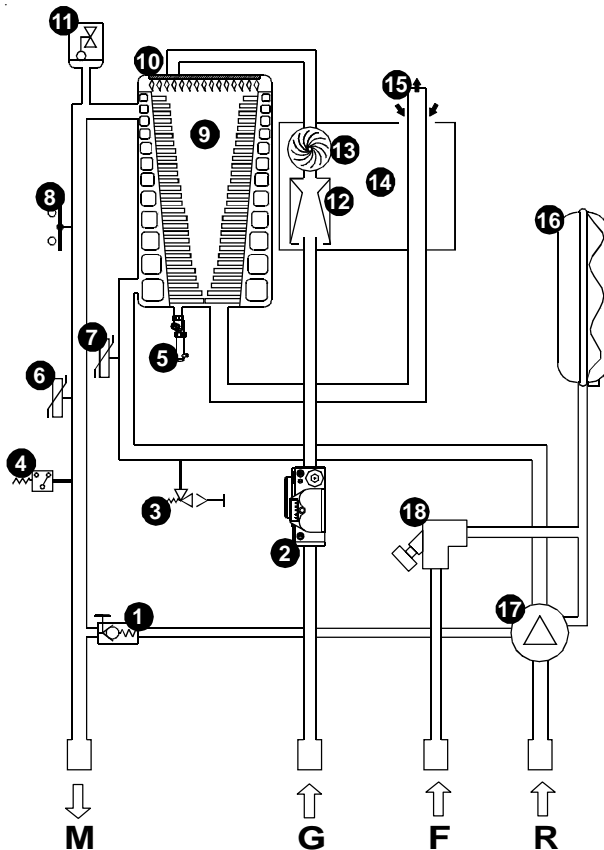

1. By-Pass
2. Gas valve
3. Central heating circuit safety valve
4. Low water pressure switch
5. Condensate drain siphon
6. Flow temperature sensor
7. Return temperature sensor
8. Safety thermostat
9. Aluminium heat exchanger/condenser
10. Burner
11. Air vent
12. Premix
13. Fan
14. Sealed chamber
15. Flue outlet/combustion air inlet
16. Expansion vessel
17. Pump
18. Filling system cock

M C.H system flow  
 G Gas inlet  
 R C.H. system return

### ALKON C

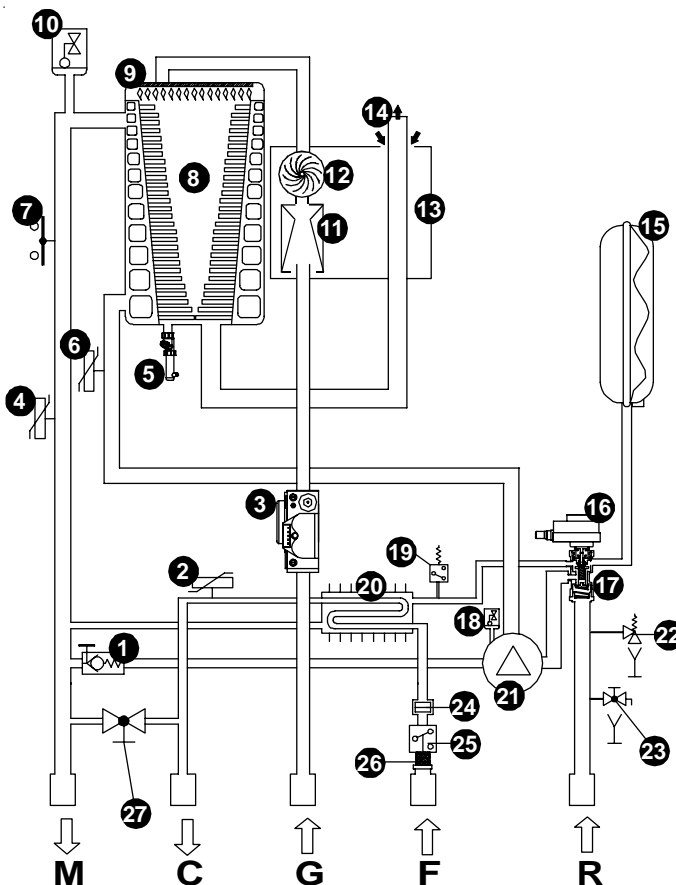

1. By-Pass
2. DHW temperature sensor
3. Gas valve
4. Flow temperature sensor
5. Condensate drain siphon
6. Return temperature sensor
7. Safety thermostat
8. Aluminium heat exchanger/condenser
9. Burner
10. Air vent
11. Premix
12. Fan
13. Sealed chamber
14. Flue outlet/combustion air inlet
15. Expansion vessel
16. Diverter valve motor
17. Diverter valve
18. Automatic air vent
19. Low water pressure switch
20. DHW plate heat exchanger
21. Circulation pump
22. Central heating circuit safety valve
23. System drain cock
24. Domestic hot water flow restrictor
25. Flow switch
26. Cold water filter
27. Filling system cock

M C.H system flow  
 C DHW outlet  
 G Gas inlet  
 F Cold water inlet  
 R C.H. system return

## Technical features and dimensions

### 2.5 - PERFORMANCE DATA ACCORDING TO STANDARD UNI 10348

For information regarding the adjustment of: INJECTORS - BURNER PRESSURES – DIAPHRAGMS – OUTPUTS – GAS CONSUMPTIONS please refer to the paragraph BURNER PRESSURE ADJUSTMENT.

	ALKON	18 R	24 R	24 C	28 R	28 C	35 R	35 C
Heat output	kW	3,4 - 17	4,3 - 23,8	4,3 - 23,8	5,6 - 28	5,6 - 28	7,0 - 34,8	7,0 - 34,8
Nominal heat input	kW	16,5	23,0	23,0	27,3	27,3	34,1	34,1
Minimum heat input	kW	3,2	4,1	4,1	5,4	5,4	6,7	6,7
Efficiency at full load (100%)	%	97,26	96,58	96,58	97,49	97,49	97,99	97,99
Required efficiency at full load (100%)	%	95,44	95,72	95,72	95,87	95,87	96,07	96,07
Efficiency at 30% part load	%	102,53	101,1	101,1	103,78	103,78	103,21	103,21
Required efficiency at part load (30%)	%	92,66	93,08	93,08	93,31	93,31	93,60	93,60
Condensing nominal heat input	kW	17,5	24,06	24,06	28,65	28,65	35,1	35,1
Condensing minimum heat input	kW	3,63	4,64	4,64	6,08	6,08	7,56	7,56
Condensing efficiency at nominal load (100%)	%	102,74	101,09	101,09	102,33	102,33	100,99	100,99
Condensing requested efficiency (100%)	%	92,24	92,38	92,38	92,46	92,46	92,55	92,55
Condensing efficiency at 30% part load	%	107,09	107,22	107,22	107,78	107,78	107,15	107,15
Condensing requested efficiency at part load (30%)	%	98,24	98,38	98,38	98,46	98,46	98,55	98,55
Number of stars (according to CEE 92/42)	n.	4	4	4	4	4	4	4
Combustion efficiency at full load (100%)	%	97,77	97,33	97,33	97,68	97,68	98,05	98,05
Combustion efficiency at reduced load	%	98,17	98,54	98,54	98,28	98,28	98,27	98,27
Stand-by losses (max)	%	0,51	0,75	0,75	0,18	0,18	0,06	0,06
(*) Flue gas temperature tf-ta (max)	°C	44,1	55,2	55,2	46	46	46,7	46,7
Flue gas mass flow rate (min-max)	g/s	1,32-7,8	1,58-10,43	1,58-10,43	2,23-12,84	2,23-12,84	2,75-15,96	2,75-15,96
Air excess	%	26,84	20,57	20,57	26,84	26,84	26,84	26,84
Condensate production max	kg/h	3,05	4,0	4,0	4,7	4,7	5,9	5,9
CO at 0% of O <sub>2</sub> (min - max)	mg/kWh	15 - 80	26 - 146	26 - 146	13 - 105	13 - 105	14 - 120	14 - 120
N0x (value according to EN 297/A3 and EN 483)	mg/kWh	46,13	57,62	57,62	49,65	49,65	38,2	38,2
N0x class		5	5	5	5	5	5	5
Flue losses with burner in operation (max)	%	2,23	2,67	2,67	2,32	2,32	1,95	1,95
Flue losses with burner off	%	0,948	0,473	0,473	0,441	0,441	0,494	0,494

(\*) Room Temperature = 20°C

Technical data registered with the appliance operating with natural gas (G20)

### 2.6 - GENERAL FEATURES

	ALKON	18 R	24 R	24 C	28 R	28 C	35 R	35 C
Appliance's family gas category		II <sub>2H3P</sub>	II <sub>2H3P</sub>	II <sub>2H3P</sub>	II <sub>2H3P</sub>	II <sub>2H3P</sub>	II <sub>2H3P</sub>	II <sub>2H3P</sub>
Min. water flow rate in CH circuit (Dt 35°C)	l/min	1,31	1,67	1,67	2,21	2,21	2,73	2,73
Min. pressure in CH circuit	bar	0,5	0,5	0,5	0,5	0,5	0,5	0,5
Max. pressure in CH circuit	bar	3	3	3	3	3	3	3
Water content in primary circuit	l	2	2,2	2,2	2,5	2,5	3	3
Max operating temp. in CH mode	°C	80	80	80	80	80	80	80
Min operating temp. in CH mode	°C	30	30	30	30	30	30	30
Total volume CH expansion vessel	l	6	8	8	8	8	10	10
Total pre-loading expansion vessel	bar	1	1	1	1	1	1	1
Max water content CH circuit (calculated for a max temp. of 90°C)	l	111,4	148,6	148,6	148,6	148,6	185,7	185,7
Min flow rate DHW circuit	l/min	-	-	2	-	2	-	2
Min. DHW inlet pressure	bar	-	-	0,5	-	0,5	-	0,5
Max DHW inlet pressure	bar	-	-	6	-	6	-	6
DHW specific flow rate (Dt 30°C)	l/min.	-	-	10,9	-	12,5	-	15
DHW flow restrictor	l/min.	-	-	12	-	12	-	14
DHW production in continuous operation with Dt 45 K	l/min.	-	-	7,2	-	8,69	-	9,82
DHW production in continuous operation with Dt 40 K	l/min.	-	-	8,1	-	9,8	-	11,1
DHW production in continuous operation with Dt 35 K	l/min.	-	-	9,2	-	11,2	-	12,6
DHW production in continuous operation with Dt 30 K (°)	l/min.	-	-	10,8	-	13	-	14,7
DHW production in continuous operation with Dt 25 K (°)	l/min.	-	-	12,9	-	15,6	-	17,7
DHW adjustable temperature	°C	-	-	35-60	-	35-60	-	35-60
Electrical supply /power consumption	V-Hz	230/50	230/50	230/50	230/50	230/50	230/50	230/50
Fuse rating	A (F)	4	4	4	4	4	4	4
Maximum absorbed power	W	130	150	150	143	143	150	150
Electrical protection	IP	X4D	X4D	X4D	X4D	X4D	X4D	X4D
Net weight	kg	32,5	33	36	33,5	37	41,5	46

(\*) mixed

3

## INSTRUCTIONS FOR THE INSTALLER

### 3.1 - GENERAL WARNINGS



**WARNING!**

This boiler has to be destined for the use for which it has been expressly designed for. Any other use shall be considered improper and therefore dangerous.

This boiler is designed to heat water at a temperature inferior to boiling point at an atmospheric pressure.



**WARNING!**

These appliances are exclusively designed to be installed inside adequate sitings.

Therefore these appliances must not be installed and operated outdoors. An outdoor installation could cause malfunctioning and could be dangerous. For external installations, it is recommended to use appliances which are specifically designed and predisposed for this purpose.



Before installing the boiler the following points have to be carried out by a competent engineer:

- a) The whole system should be thoroughly flushed in order to remove any residual dirt or grime which could compromise correct boiler operation.
- b) Check that the boiler has been preset for operating with the gas type available. This is verifiable via the indication on the packaging and on the data badge;
- c) Check that the chimney/flue pipe has an adequate draught, does not have any constrictions, and that no other appliance's flue outlets have been fitted, unless the chimney is serving more than one heating appliance, according to the specific standards and regulations in force. The connection between the boiler and chimney/flue outlet can be made only after this verification has been carried out.



**WARNING!**

In rooms where aggressive vapours or dust is present the appliance must operate independently from the air present in the boiler's location room!



**WARNING!**

The appliance must be installed by a qualified engineer, who complies to the technical-professional requirements according to the law 46/90 and whom, under his own responsibility, guarantees the compliance of the standards according to the latest regulations.



**WARNING!**

The appliance must be installed only on a vertical flat wall, made of non combustible material.

The appliance must be positioned so that at least the minimum operational and servicing clearances are provided.



**NOTE:**

The boiler must be connected to a heating system which is compatible to its performance and output.

## Instruction for the installer

### 3.2 – STANDARD CODES FOR INSTALLATION

The **ALKON** boiler is a thermal unit designed for use with the family gas category II<sub>2H3F</sub>.

The appliance must be installed in compliance to the instructions contained in this manual.

The installation must be carried out by a competent qualified engineer, **whom will assume the responsibility of complying to all the local and/or national regulations published in the official publications, as well as all the applicable codes of practice.**

The installation must be carried in accordance to the codes of practice, the regulations and the requirements hereby indicated, which constitute an indicative list, but not a complete one, as these continue to undergo developments.

National installation regulations:

Gas plants for domestic use fed by network distribution  
Standard UNI-CIG 7129

Gas plants for domestic use not fed by network distribution  
Standard UNI-CIG 7131  
Law dated 5.03.90 n°46  
Law dated 9.01.91 n°10

Other applicable statutory requirements:  
Law 1083/71 (ref. Standard UNI for the design, installation and maintenance).  
Law 46/90 and D.P.R. 447/91  
Law 10/91 and D.P.R. 412/93 and subsequent amendments  
D.M 1.12.1975

Moreover, the boiler must be installed in accordance to all the regulations regarding the boiler room, and comply to the building regulations and the prescriptions regarding central heating plants in force in the country the boiler is installed.

The appliance must be installed, commissioned and serviced according to the regulations in force. This is also valid for the hydraulic system, the flue outlet system and the boiler location room.

### 3.3 - PACKAGING

The **ALKON** range of boilers are supplied fully assembled in a strong cardboard box.



After having unpacked the boiler check that it is intact and undamaged.



Keep the packaging material (cardboard box, plastic bags, polyester protection etc.) **out of the reach of children as they can be dangerous.**

**UNICAL** refuses all liability for injury to persons, animals or damage to property deriving from not having respected the above mentioned recommendations.

In the packaging, in addition to the boiler, you can also find the following contents:

- Service logbook
- User's instruction guide
- This installation and servicing manual
- Warranty
- Nr. 2 spare parts request coupons
- N° 2 wall plugs for fixing the boiler to the wall
- Pipe kit
- Wall mounting template



**Note:**  
**DO NOT DISPOSE OF PACKAGING IN THE ENVIRONMENT**

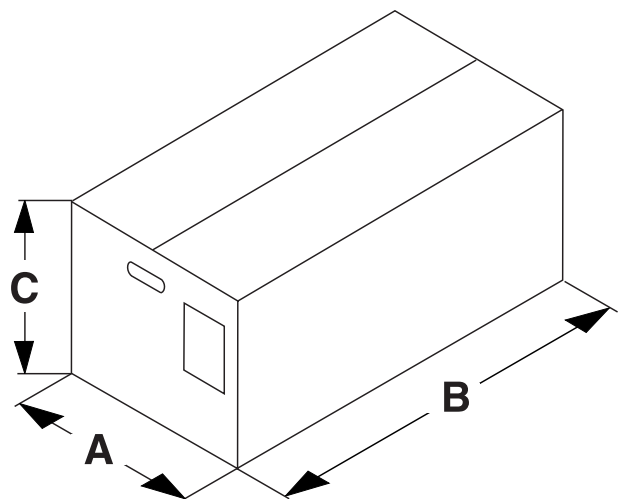

	ALKON		
	18	24 - 28	35
A	435	484	535
B	794	844	844
C	414	414	414

### 3.4 - BOILER LOCATION

When selecting the position for the installation of the boiler please comply to the following safety requirements:

- Fit the appliance in rooms protected from frost;
- In rooms where aggressive vapours or dust are present, the appliance must be able to operate independently from the air of the location room;
- The appliance must be installed exclusively on a vertical and solid wall, capable of adequately supporting the weight of the boiler;
- The wall must not be made of inflammable material;
- Leave a clearance of 50mm on each side of the boiler to facilitate subsequent servicing;

Every appliance is supplied with a steel "Wall mounting template" which facilitates the connection of the gas and water feed pipes when laying out the hydraulic system and before installing the boiler.

This template has to be fixed on to the wall chosen for the installation.

The upper part of the template marks the position where to drill the holes for fixing the boiler support bracket to the wall.

The lower part of the template marks the correct positioning of the system pipework connections for the following parts:

- M** = CH system flow (3/4")
- C** = Hot water outlet (1/2")
- G** = Gas supply (3/4")
- F** = Cold water supply (1/2")
- R** = CH system return (3/4")

**ALKON 24/28/35 STEEL WALL MOUNTING TEMPLATE**  
CODE: 00212518

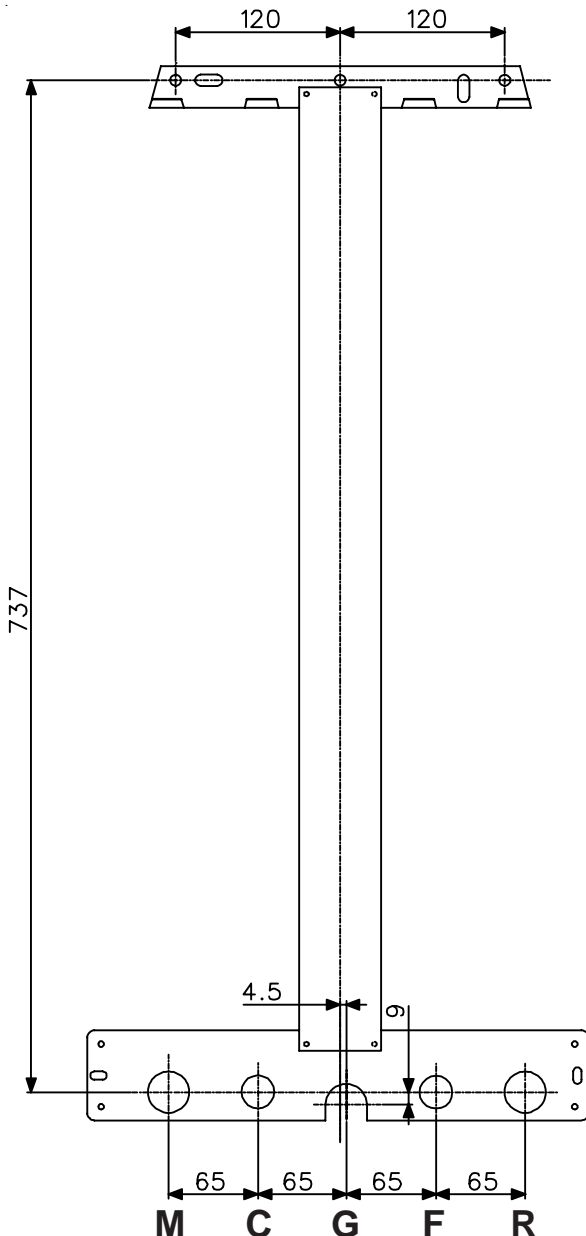

**ALKON 18 STEEL WALL MOUNTING TEMPLATE**  
CODE: 00212566

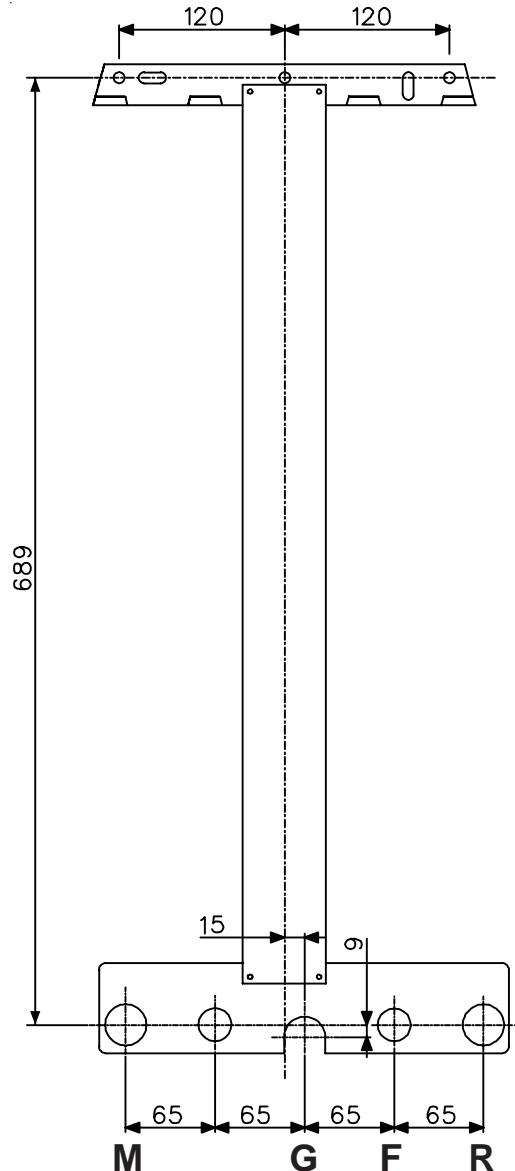

## Instruction for the installer

### HOW TO POSTION THE WALL MOUNTING TEMPLATE ON TO THE WALL

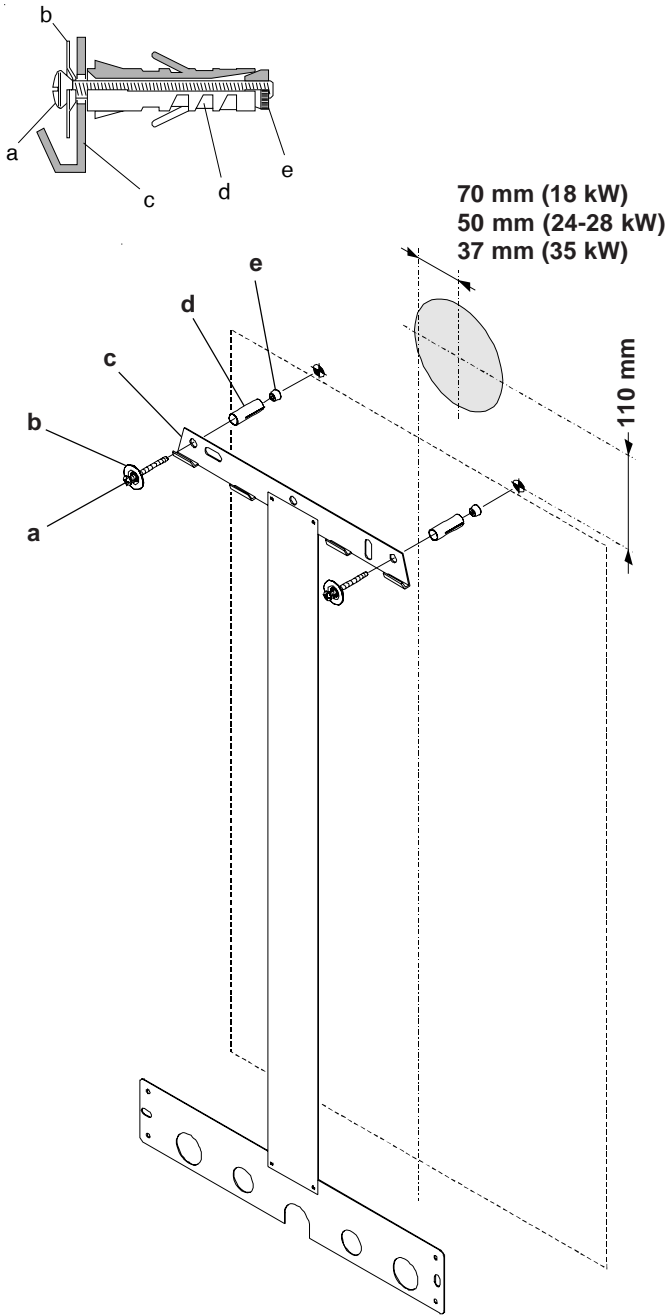

### POSITIONING OF THE SYSTEM PIPEWORK CONNECTIONS, CONDENSATE DRAIN AND PRESSURE RELIEF VALVE

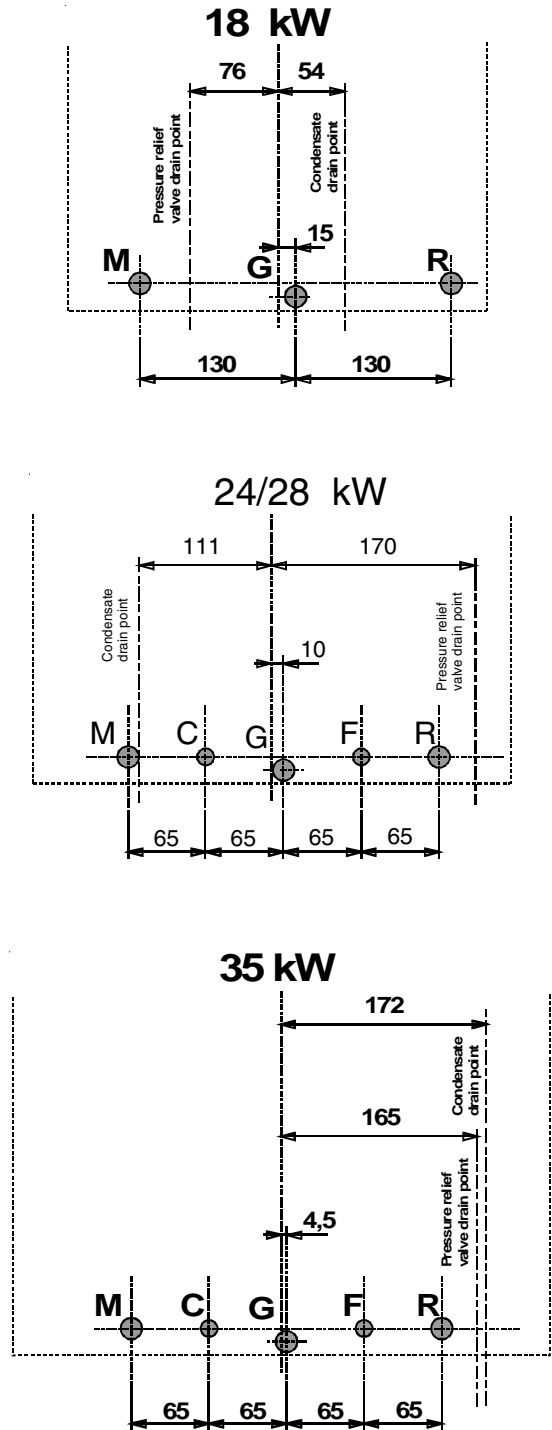

**Note:**

The pipework for the condensate drain point and pressure relief valve must be fitted under the lower part of the boiler.

**Dimensions for the connection of the ALKON R 18 to the external storage tank kit DSP 110**

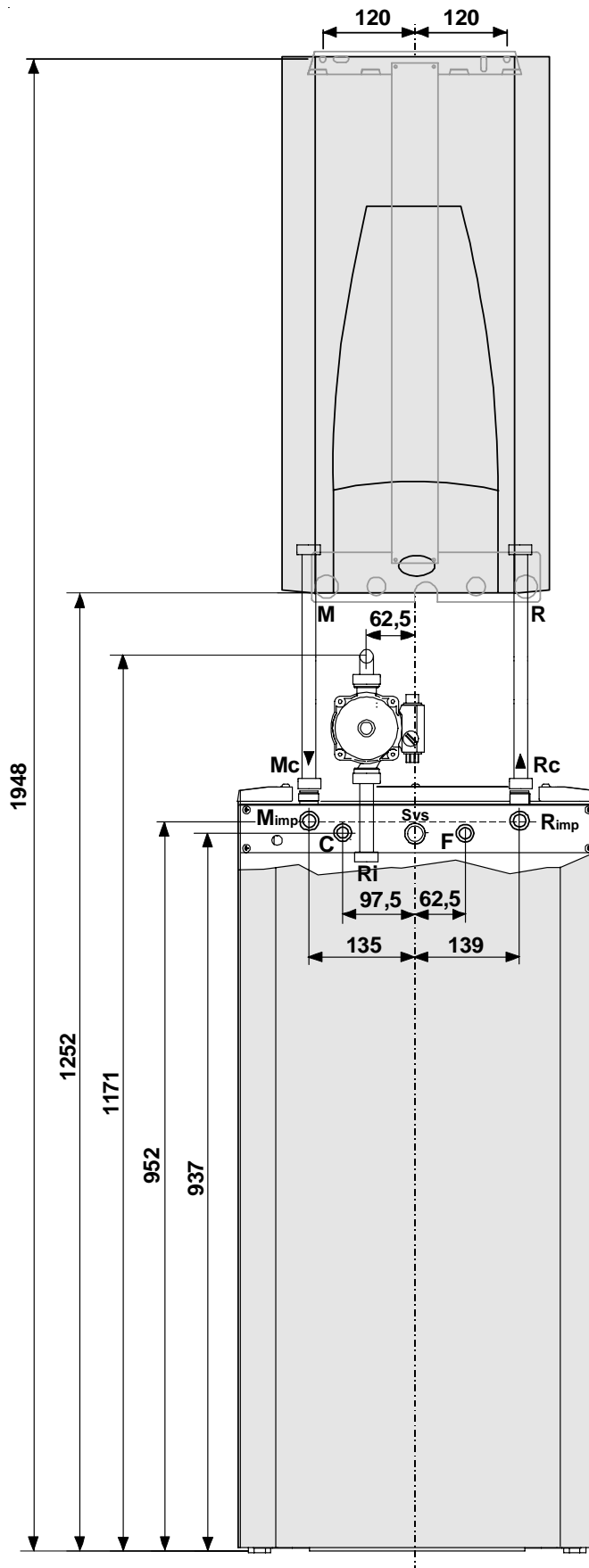

## Instruction for the installer

### 3.5 - BOILER INSTALLATION

Before connecting the boiler to the heating system the following requirements must be carried out by competent and qualified engineers:

- The system is flushed out with a suitable product in order to eliminate any metallic tooling or welding residues and oil and grime which could reach the boiler and affect the proper running of the boiler;
- Check that the boiler has been preset for operating with the gas type available.  
This is verifiable via the indication on the packaging and on the data badge;
- Check that the chimney/flue pipe has an adequate draught, does not have any constrictions, and that no other appliance's flue outlets have been fitted, unless the chimney is serving more than one heating appliance, according to the specific standards and regulations in force. The connection between the boiler and chimney/flue outlet can be made only after this verification has been carried out.

For fitting the boiler:

- Place the steel mounting template on to the wall.
- Determine the position of the holes for fixing the support bracket.
- Drill the holes and fix the support bracket using the fixing screws as indicated on page 14.
- Engage the boiler on to the support bracket.
- Mark the positions of the gas, cold water supply, hot water outlet, CH flow and return, pressure relief valve and/or condensate drain.



**Note: The appliances are equipped with expansion vessels. Before installing the appliance check that the vessel's capacity is sufficient; if this is not the case, provision must be made to fit an additional expansion vessel.**

### 3.6 - GAS CONNECTION



#### **DANGER!**

The gas connection must be carried out only by a qualified engineer who will have to respect and comply to the regulations in force and to the requirements indicated by the local gas supplier. An incorrect installation could cause injury to persons, animals or damage to property. The manufacturer shall not be held liable for any injury and/or damage.



Before installing the boiler it is recommended to thoroughly clean all the fuel feed pipework in order to remove any eventual residual grime which could compromise the boilers correct functioning.



If you smell gas:

- Do not turn on or off electrical switches, use the telephone or any other object which can provoke sparks;
- Open all doors and windows in order to allow fresh air to enter and purify the room;
- Close all gas cocks;
- Contact a service engineer, qualified installer or the gas supply company.



As a safety measure against gas leaks, Unical recommends installing a surveillance and protective system composed of a gas leakage detector combined with an on-off selenoid valve fitted on the gas supply line.

The gas supply pipe must have a section which is identical or greater than the one used on the boiler and must assure a correct gas pressure.

It is however important to comply with the "General installation standards" indicated in the standards UNI 7129, UNI 7131 and UNI 1137-1.

Before commissioning an internal gas distribution system and therefore before connecting it to the gas meter, the complete installation must be tested for gas soundness.

If any part of the system is concealed from view the gas soundness test must be carried out before covering the pipes.

Before connecting the pipework the system must be tested with air or inert gas at a pressure of at least 100mbar.

Before commissioning the boiler ensure that the following operations are carried out:

- Open the gas meter cock and vent the air contained in the piping and subsequently proceed to vent device by device.
- Check, with the gas cock turned off, that there are no gas leaks. During the 2<sup>nd</sup> quarter of the hour from the start of the test, no pressure reduction should be detected by the pressure gauge. Any gas leaks must be found by using only water soap solutions, or an equivalent product, and eliminated. **Never look for gas leaks using a naked flame.**



### 3.7 - CENTRAL HEATING CONNECTIONS



**WARNING!**

**Before installing the boiler we recommend that the system is flushed out with a suitable product in order to eliminate any metallic tooling or welding residues, oil and grime which could reach the boiler and affect the proper running of the boiler.**

**Do not use any solvents for flushing out the system as they could damage the system and/or its components.**

**Non-observance of these instructions could cause injury to persons, animals or damage to property. The manufacturer shall not be held liable for any such injury and/or damage.**

The CH flow and return circuits have to be connected to the boiler via the respective connections ¾" M and R as indicated on page 14.

When determining the size of the CH circuit pipes it is essential to bear in mind the pressure losses induced by the radiators, any eventual thermostatic radiator valves, lockshield valves and by the system's layout.

The routing of the piping has to be laid down taking all the necessary precautions in order to avoid air locks and to facilitate the continuous purging of the system.



**Ensure yourself that the system's piping is not used as earth clamps for the electrical or telephonic system. They are absolutely unsuitable for this use. In a short time this could cause serious damage to the piping, boiler and radiators.**

The boiler is fitted with an automatic BY-PASS (differential valve with a flow rate of about 150 l/h) which always ensures a minimum water flow rate to the heat exchanger even if, for example, all the thermostatic valves fitted on the heating system are closed.

It is possible to adjust the by-pass by acting on the adjustment screws.

**Alkon C**  
By-pass adjustment

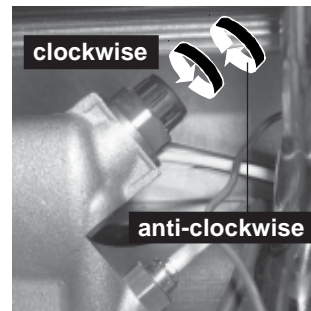

**Alkon R**  
By-pass adjustment

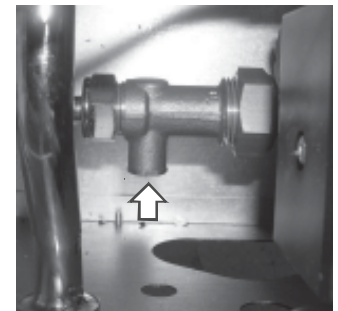

**By-Pass CLOSED**  
rotate the screw in a clockwise direction



**By-Pass OPEN**  
rotate the screw in a anti-clockwise direction



**Pressure relief valve drain pipe**

In correspondence to the heating pressure relief valve provision should be made to install a discharge pipe with a funnel and a siphon which lead to an adequate drainage. The drainage has to be controllable by sight.



**WARNING!**

**If this precaution is not taken it could lead to injury to persons, animals or damage to property.**

**The manufacturer shall not be held liable for any such injury and/or damage.**

## Instruction for the installer

### BOILER CIRCULATION PUMP

Graph - Water flow rate/ available head for installation – ALKON 18 kW

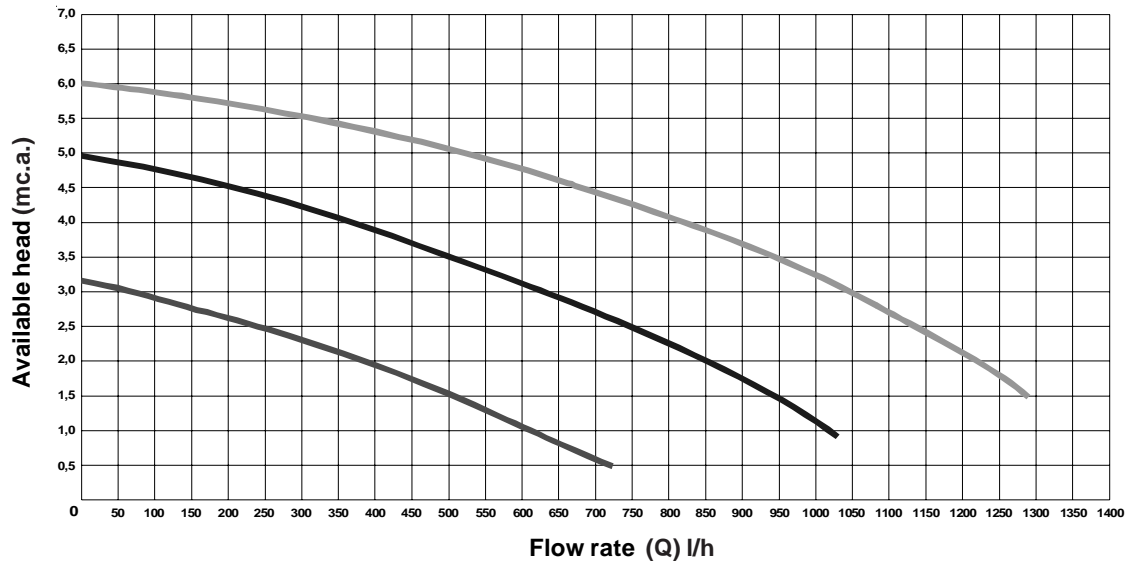

### BOILER CIRCULATION PUMP

Graph – Water flow rate/ available head for installation– ALKON 24 kW

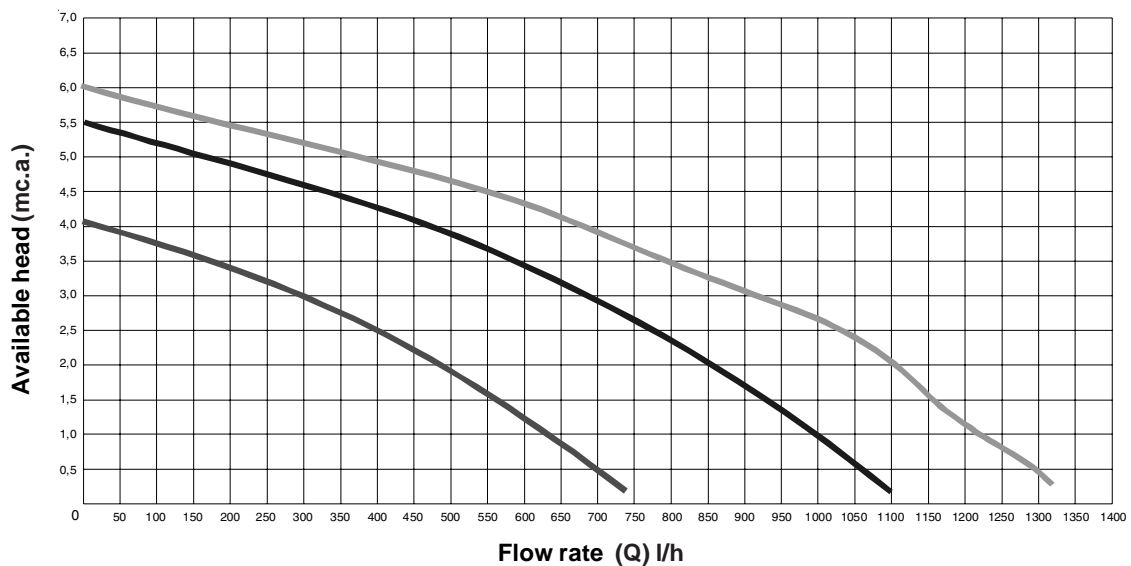

### BOILER CIRCULATION PUMP

Graph – Water flow rate/ available head for installation– ALKON 28 kW

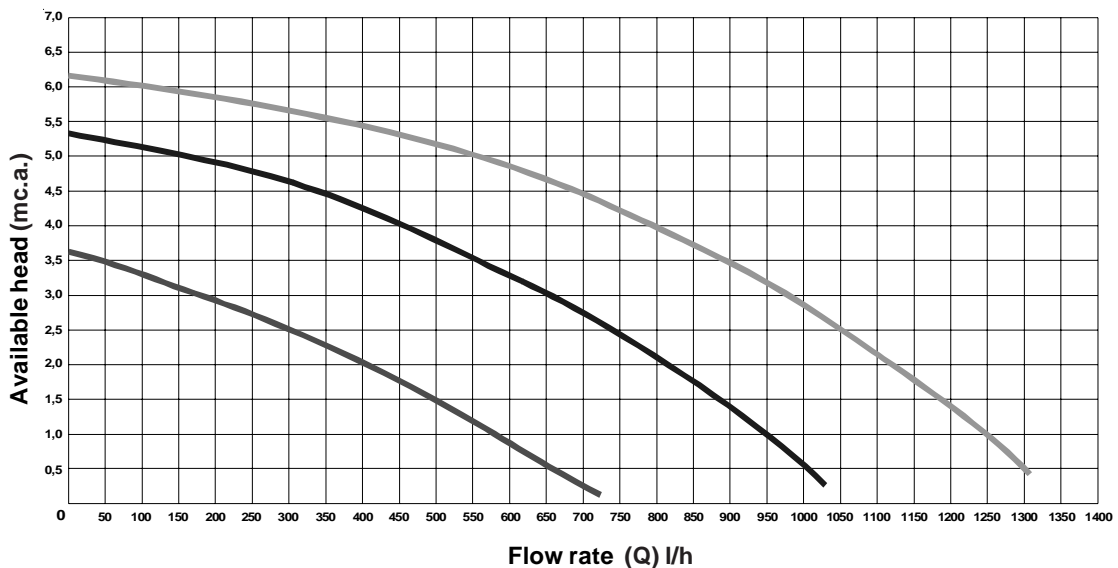

**BOILER CIRCULATION PUMP**

Graph – Water flow rate/ available head for installation– ALKON 35 kW

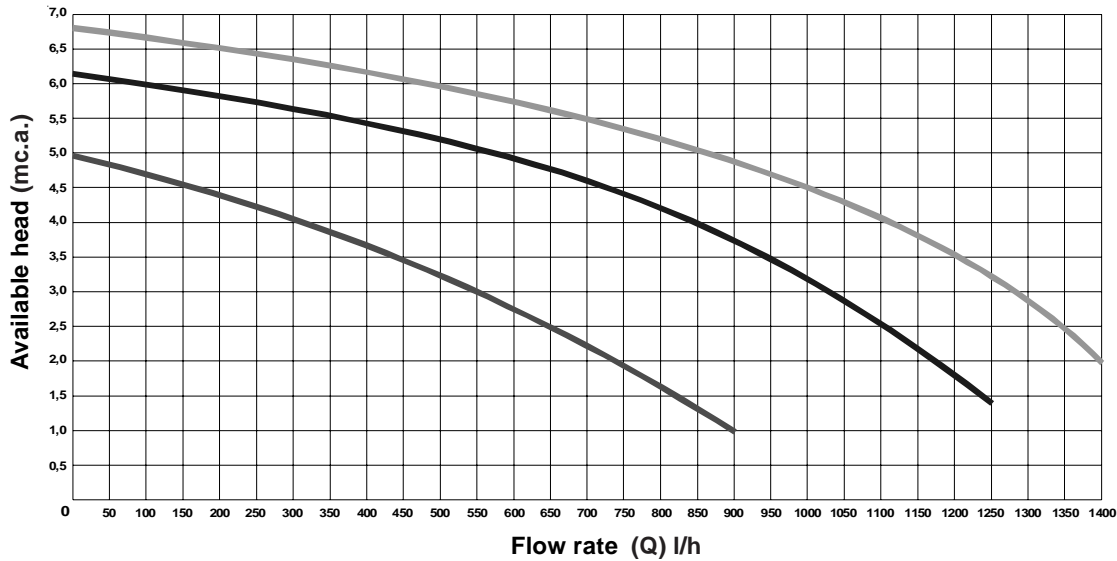

**3.8 - DOMESTIC HOT WATER CONNECTIONS (Model "C")**



**WARNING!**

Before connecting the boiler to the water mains supply ensure that the system is flushed out with a suitable product in order to eliminate any metallic tooling or welding residues, oil and grime which could reach the boiler and affect the proper running of the boiler.

Non-observance of these instructions could cause injury to persons, animals or damage to property. The manufacturer shall not be held liable for any such injury and/or damage.

The hot water distribution and domestic hot water supply pipework must be connected to their respective ½ boiler pipe connections C and F as indicated on page 14.



The pressure in the system must be between 1 and 3 bar (if the pressure is higher fit a reducing pressure valve).



**WARNING!**

The hardness of the mains water supply conditions the frequency with which the DHW heat exchanger is cleaned.

In hard water areas the opportunity of fitting an adequate scale reducing device for domestic purposes for treating the mains water supply to the boiler, in compliance to the DM n°443 dated 21/12/90, should be taken into consideration.

Where water hardness exceeds 15°f, a scale reducing device is always recommended.



Ensure yourself that the system's water and central heating piping are not used as earth clamps for the electrical or telephonic system. They are absolutely unsuitable for this use. In a short time this could cause serious damage to the piping, boiler and radiators.

**3.9 - EXAMPLES OF SYSTEM PIPEWORK CONNECTIONS**

**CONNECTION WITH STRAIGHT PIPES**

00360724 Straight pipework kit (supplied with the boiler)

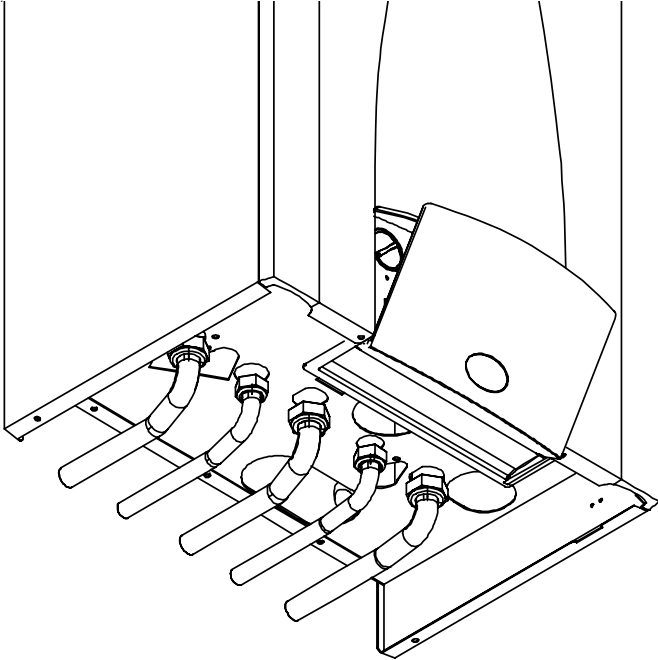

**CONNECTION WITH STRAIGHT PIPES + ON-OFF VALVES**

00360724 (supplied with the boiler)  
00360682 (optional extra)

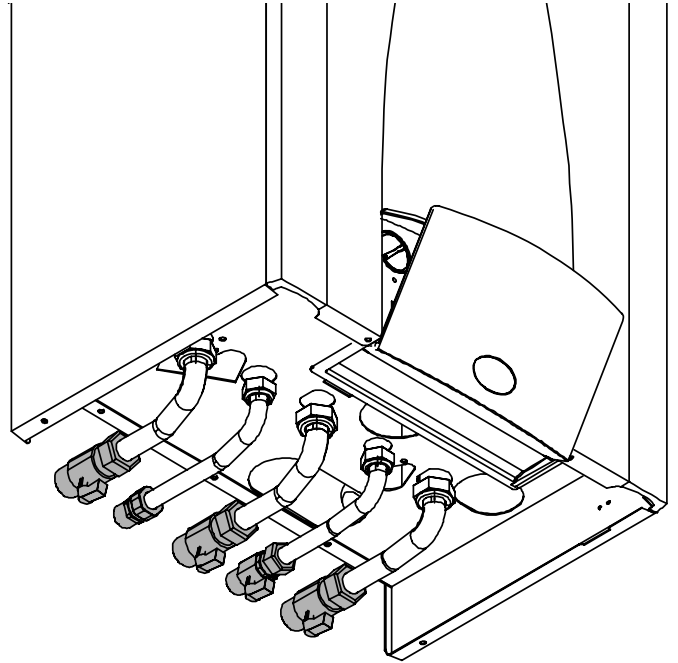

**CONNECTION WITH STRAIGHT PIPES + BICONIC NIPPLES**

00360724 Straight pipework kit supplied with the boiler)  
00361382 Telescopic pipes connection kit (optional extra)

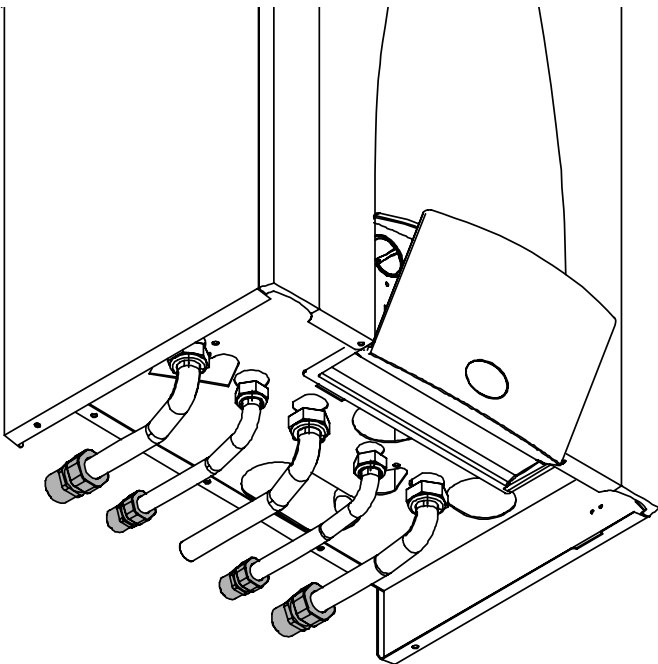

### 3.10 - CONDENSATE DRAIN

During the combustion process the boiler produces condensate which, through the "A" pipe, flows into the siphon. The condensate which forms inside the boiler has to be routed into an adequate drain by means of the pipe "B".



**DANGER!**  
**Before commissioning the appliance fill the siphon and check the correct drainage of the condensate.**  
**If the appliance is used with the condensate drain siphon empty there could be danger of intoxication resulting from the escape of flue gasses.**

The connection between the appliance and the sewage system must be carried out in compliance with the specific reference standards, and in particular:

- prevent the end user utilizing the condensate produced;
- a siphon must be fitted (supplied with the boiler);
- there must be no bottlenecks;
- the connection must be made just under the bottom part of the boiler;
- it must be installed so as to avoid freezing of the liquid when the boiler is operating and prevent the eventual pressurization of the sewage system;
- consent the correct downflow of the appliance's liquid discharges;
- it must be made with one of the following materials which are resistant to condensate:
  - Grès, according to the Standards DIN 1230-1 and 6, EN 295-1 or 2 or 3;
  - Glass (boron silicate);
  - Polyvinyl chloride (PVC), according to DIN V 19534-1 and 2, and DIN 19538;
  - Polyethylene (PE) DH type, according to DIN 19535-1 and 2 and DIN 19537-1 and 2;
  - Polypropylene (PP) and copolymer styrene (ABS) according to DIN V 19561;
  - Polyesterific resin (GF-UP), according to DIN 19565-1;
  - Stainless steel.

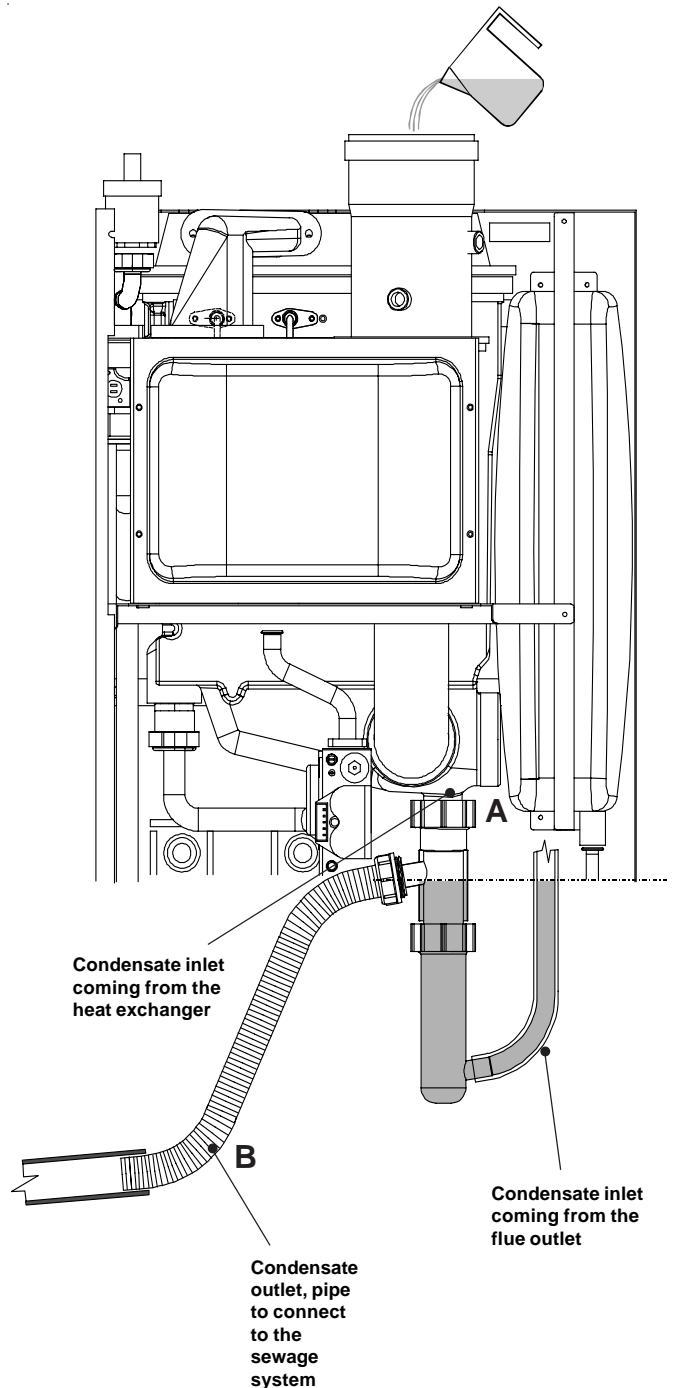

## Instruction for the installer

### 3.11 - FLUE OUTLET INSTALLATION

The flue system must be installed in accordance with the local and national Standards (refer to Standard UNI-CIG 7129, point 4 and UNI-CIG point 5)



We recommend using only original UNICAL flue outlet systems. Damages caused by installation errors and for non-observance of the instructions given by the same manufacturer will invalidate all the supplier's contractual or extra contractual responsibilities.

If the boiler has to be replaced **ALWAYS** replace the flue outlet system.

The boiler has been approved for the following flue configurations:

- C13** Boiler designed for connection to horizontal inlet and outlet terminals, which admit fresh air to the burner and discharge the products of combustion to the outside through concentric or twin ducts. The minimum distance between the inlet air duct and the flue outlet duct must be of 250 mm and both terminals must be positioned within a 500 mm square section.

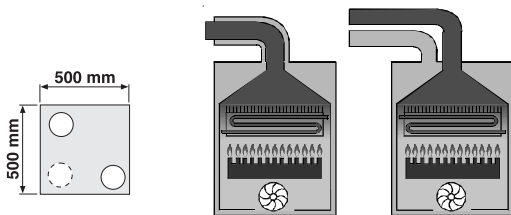

- C33** Boiler designed for connection to vertical inlet and outlet terminals, which admit fresh air to the burner and discharge the products of combustion to the outside through concentric or twin ducts. The minimum distance between the air inlet duct and the flue gas outlet duct must be of 250 mm and moreover both terminals must be positioned within a 500 mm square area.

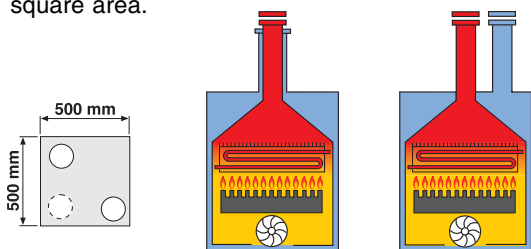

- C43** Boiler designed for connection to collective flue systems including two ducts, one for the air inlet and the other for the discharge of products of combustion through concentric or twin ducts.

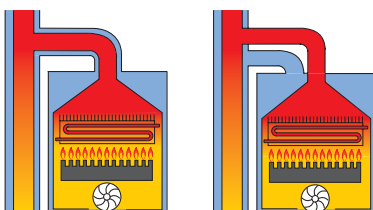

- C53** Boiler with separate air inlet and products outlet. These ducts can discharge into areas with different pressure. **The two terminals must not be fitted on to two opposite walls.**

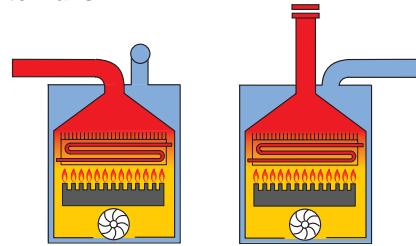

#### Type C63

Boiler designed for connection to a combustion air inlet and flue products discharge system approved and sold separately.

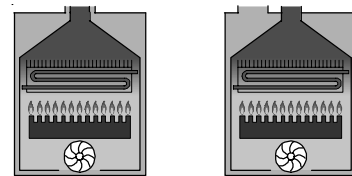

- C83** Boiler designed for connection to a terminal for the intake of combustion air and to an individual or collective chimney for the discharge of the products of combustion. **The chimney must comply to the current regulations.**

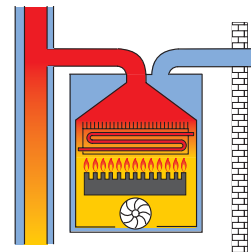

- B23** Boiler designed to be connected to an open flue which will terminate vertically through the roof. The combustion air is withdrawn directly from the room where the boiler is installed.

**WARNING: for this type of connection the room must comply with the same installation regulations valid for open chimney boilers.**

**The chimney must comply to the current regulations.**

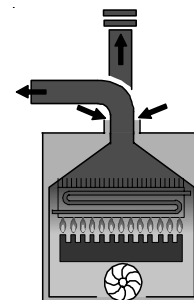

**HORIZONTAL FLUE OUTLET WITH CONCENTRIC DUCTS Ø 60/100 mm**

**Type C13**

The minimum allowable length of the horizontal concentric pipes is of 0,75 metres.

The maximum allowable length of the horizontal concentric pipes is of 3,5 metres. For each elbow added the maximum length permitted has to be reduced by 1 metre.

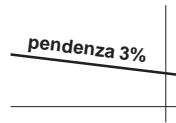

**Important:** the outlet/inlet flue has to have a minimum inclination of 3% towards the top in the outlet direction, so as to enable the collection of any condensate formed in the boiler.

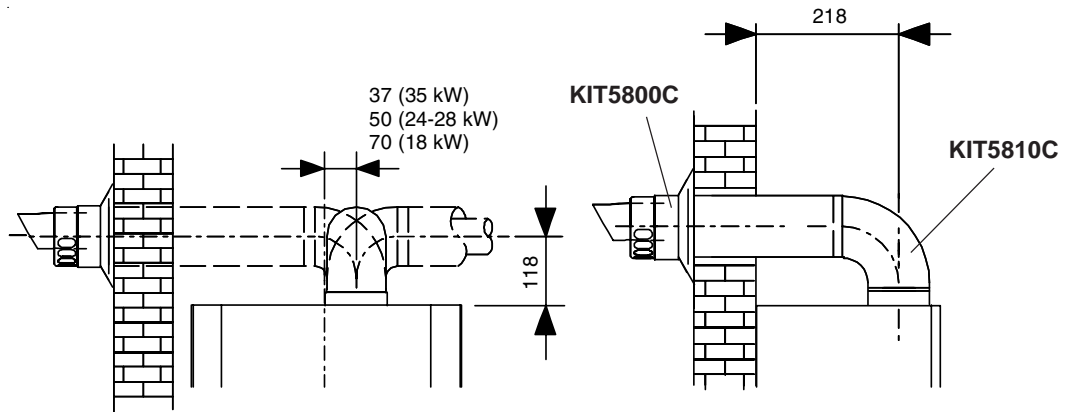

**Type C33**

The maximum allowable length of the vertical concentric pipes is of 8,5 metres, apart from the terminal Ø 80/125. For each elbow added the maximum length permitted has to be reduced by 1 metre.

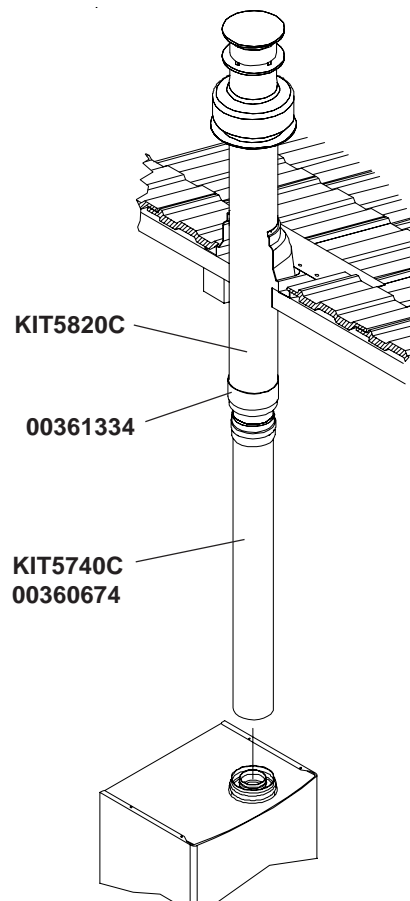

## Instruction for the installer

### HORIZONTAL FLUE OUTLET WITH CONCENTRIC DUCTS $\text{D} \bullet 80/125 \text{ mm}$

#### Type C13

The minimum allowable length of the horizontal concentric pipes is of 0,75 metres.

The maximum allowable length of the horizontal concentric pipes is of 6 metres. For each elbow added the maximum length permitted has to be reduced by 1 metre. Moreover, the flue outlet has to have a minimum inclination of 3% towards the top in the outlet direction, so as to enable the collection of any condensate formed in the boiler.

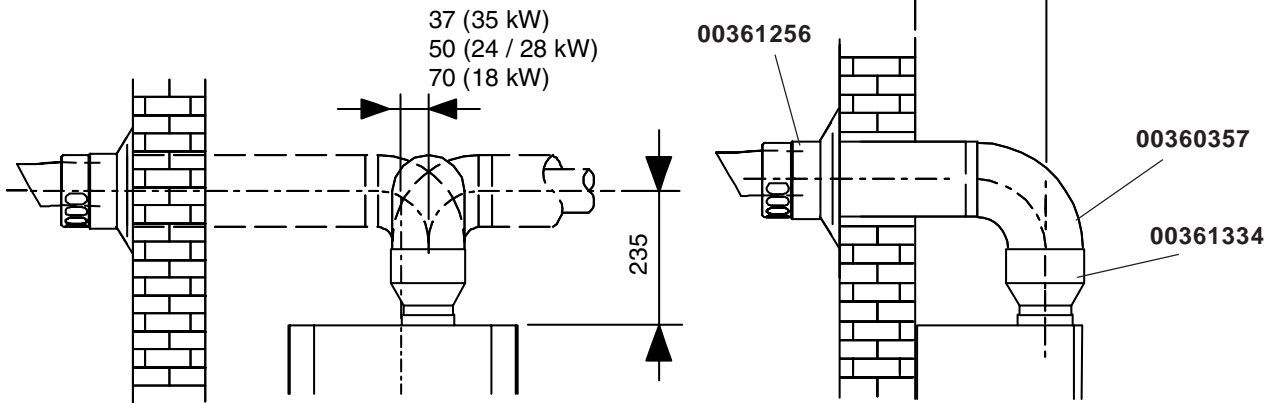

#### Type C33

The maximum allowable length of the vertical concentric pipes is of 8,5 metres, including the terminal  $\text{Ø} 80/125$ . For each elbow added the maximum length permitted has to be reduced by 1 metre.

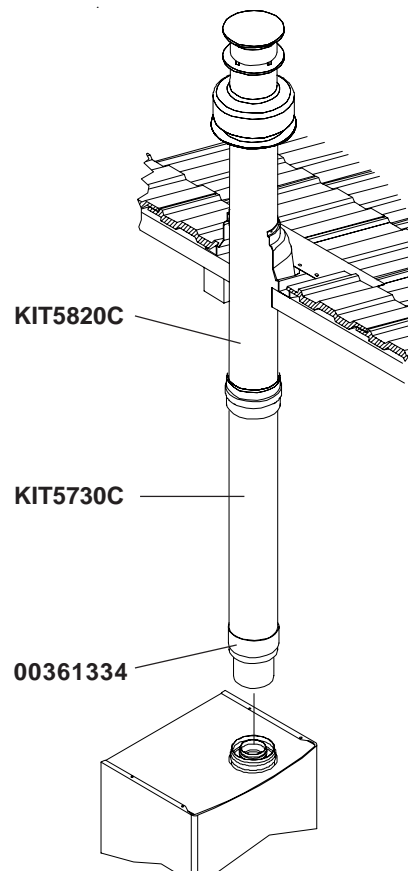



**FLUE OUTLET WITH SEPARATE DUCTS D• 80 mm**

The maximum pressure loss permitted, independently from the type of installation, must not exceed the value of 100 Pa.

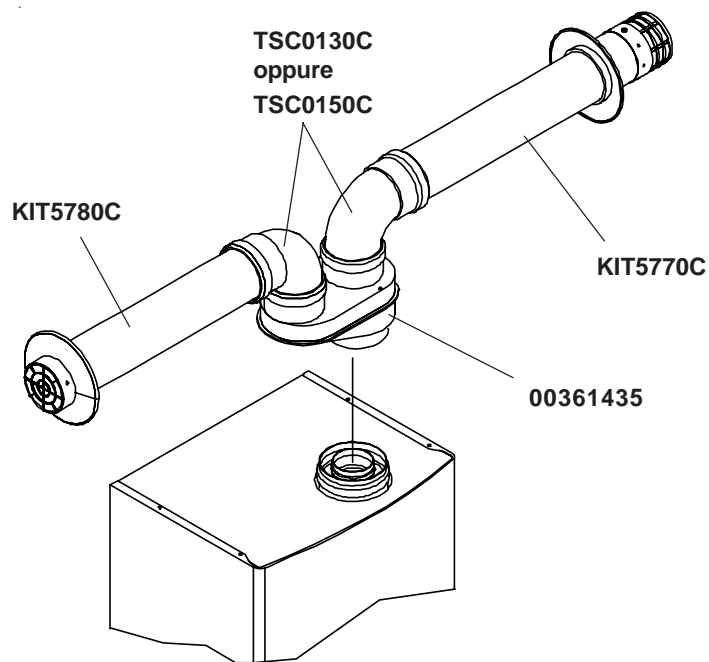
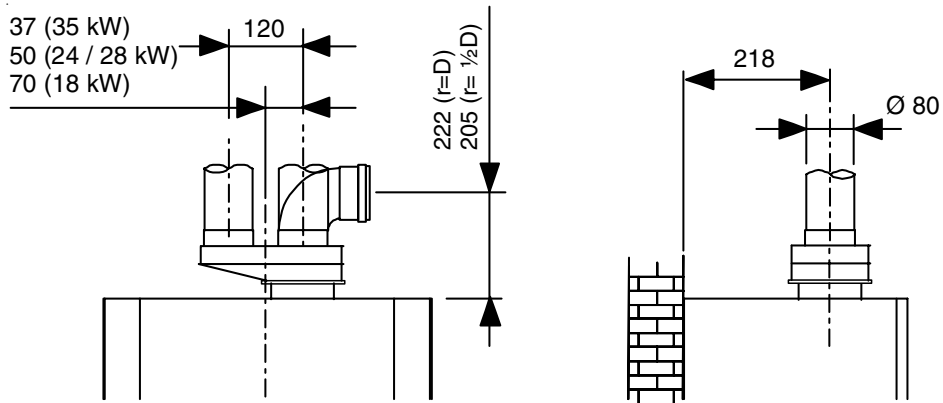

**It is not permitted to position the two terminals on opposite walls.**

## Instruction for the installer

### FLUE CONFIGURATION Ø 80 mm

The maximum allowed pressure drop, apart from the installation type, cannot be higher than 100 Pa.

#### Example N.1

Intake of primary air from the perimeter wall and flue outlet from the roof.

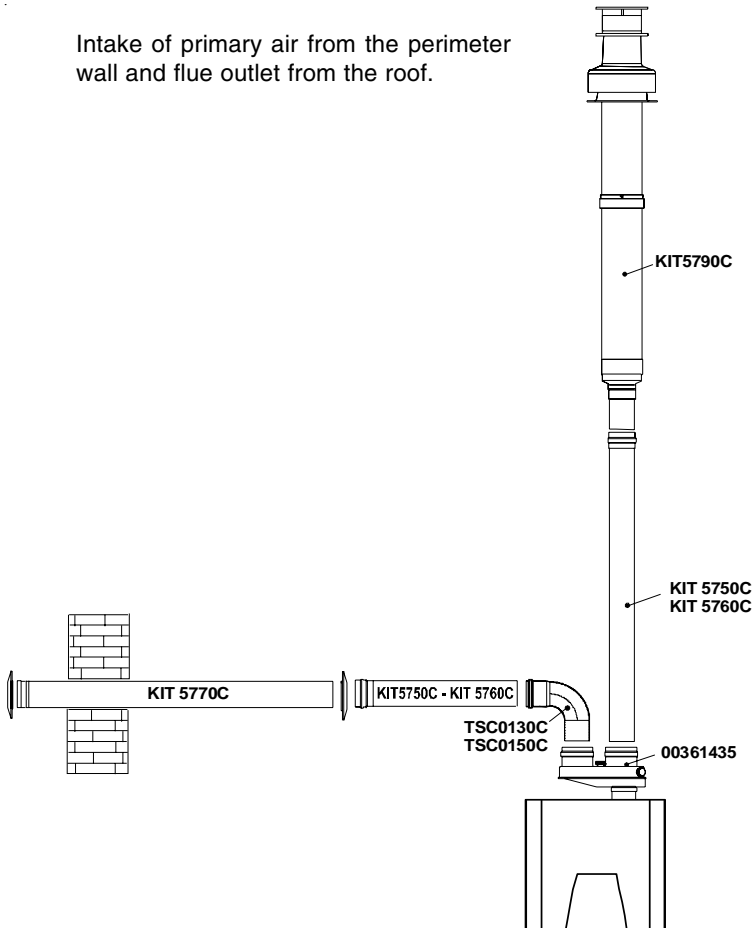

### CALCULATION OF THE PRESSURE LOSSES OF THE COMBUSTION AIR INLET/PRODUCTS OUTLET DUCTS

When calculating the pressure losses bear in mind the following parameters:

- For the twin flue pipe system's adaptor, the pressure loss is of 4 Pa;
- For narrow radius 90° bend Ø 80 (R=½ D), the pressure loss is of 14 Pa;
- For each large radius 90° bend Ø 80 (R=½ D), the pressure loss is of 4 Pa;
- For each metre of Ø 80 flue pipe the pressure loss is of 1 Pa in the combustion air inlet;
- For each metre of Ø 80 flue pipe the pressure loss is of 1,5 Pa in the combustion product outlet;
- For the Ø 80 L=1 horizontal combustion air inlet terminal the pressure loss is of 3,5 Pa;
- For the Ø 80 L=1 horizontal combustion products outlet terminal the pressure loss is of 5,5 Pa;
- For the vertical flue outlet duct Ø 80 L=1 the pressure loss is of 8 Pa.



**Note:** These values refer to flue systems made with original UNICAL non flexible and smooth pipes.



The maximum pressure drop of 100 Pa includes the losses created by:

- 1 adaptor from 1 x Ø60/100 mm to 2 x Ø80 mm
- 2 wide radius curves +
- 1 exhaust terminal +
- 1 air intake terminal

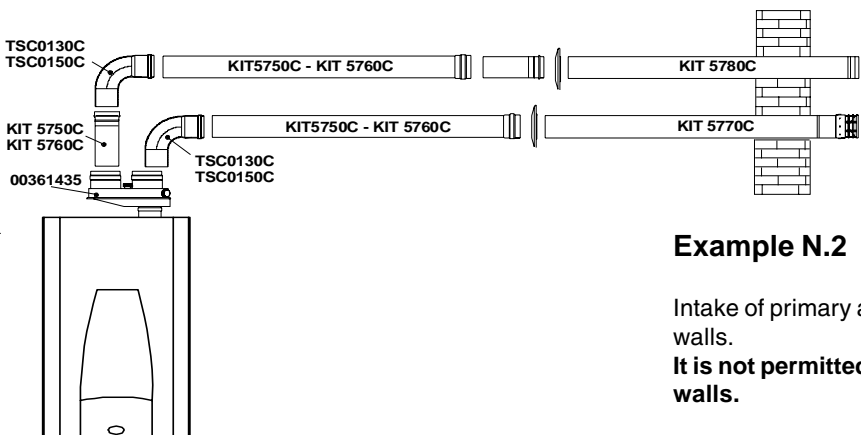

#### Example N.2

Intake of primary air and flue outlet from two external perimeter walls.

**It is not permitted to position the two terminals on opposite walls.**

## FLUE CONFIGURATION Ø 60 mm

The maximum allowed pressure drop, apart from the installation type, cannot be higher than 60 Pa.

### Example N.1

Intake of primary air from the perimeter wall and flue outlet from the roof.

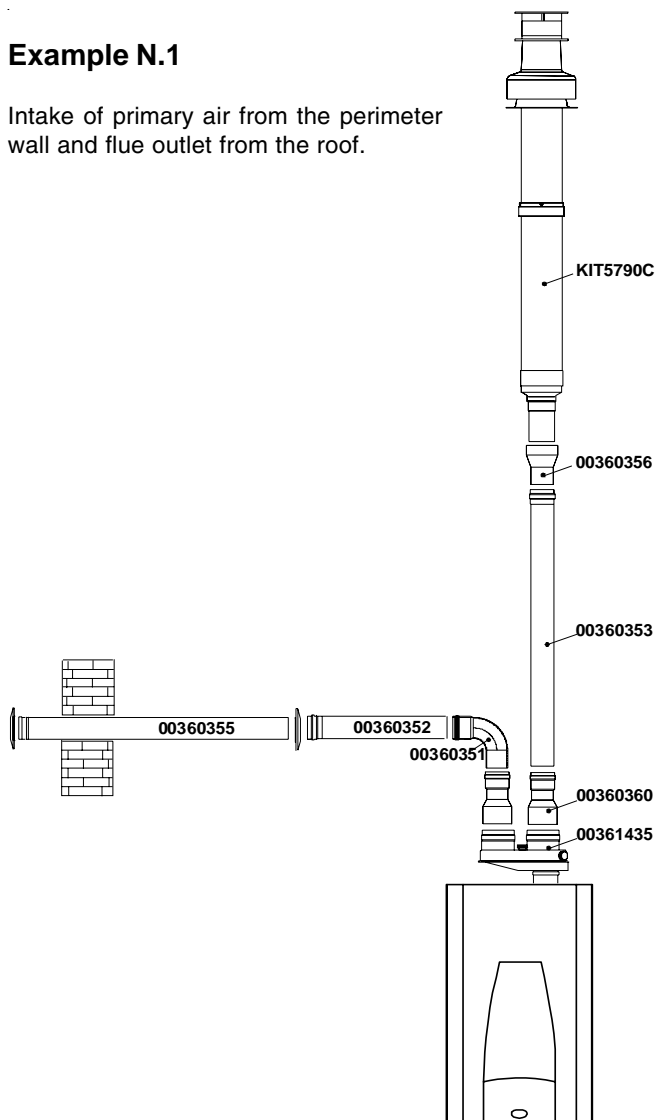

## CALCULATION OF THE PRESSURE LOSSES OF THE COMBUSTION AIR INLET/PRODUCTS OUTLET DUCTS

When calculating the pressure losses bear in mind the following parameters:

- For the twin flue pipe system's adaptor, the pressure loss is of 4 Pa;
- For reducer M Ø80 / F Ø60 the pressure drop is 6 Pa in evacuation and 3 Pa in suction
- For reducer F Ø80 / M Ø60 the pressure drop is 6 Pa in evacuation and 3 Pa in suction
- For each large radius 90° bend Ø 60 (R=D), the pressure loss is of 4 Pa;
- For each metre of Ø 60 flue pipe the pressure loss is of 3 Pa in the combustion air inlet;  
For each metre of Ø 60 flue pipe the pressure loss is of 5 Pa in the combustion product outlet;
- For the Ø 60 L=1 horizontal combustion air inlet terminal the pressure loss is of 6 Pa;
- For the Ø 60 L=1 horizontal combustion products outlet terminal the pressure loss is of 10 Pa;
- For the vertical flue outlet duct Ø 80 L=1 the pressure loss is of 8 Pa



**Note:** These values refer to flue systems made with original UNICAL non flexible and smooth pipes.



The maximum pressure drop of 60 Pa includes the losses created by:

- 1 adaptor from 1 x Ø60/100 mm to 2 x Ø80 mm
- 2 wide radius curves +
- 1 exhaust terminal +
- 1 air intake terminal +
- 2 reducer M Ø80 / F Ø60

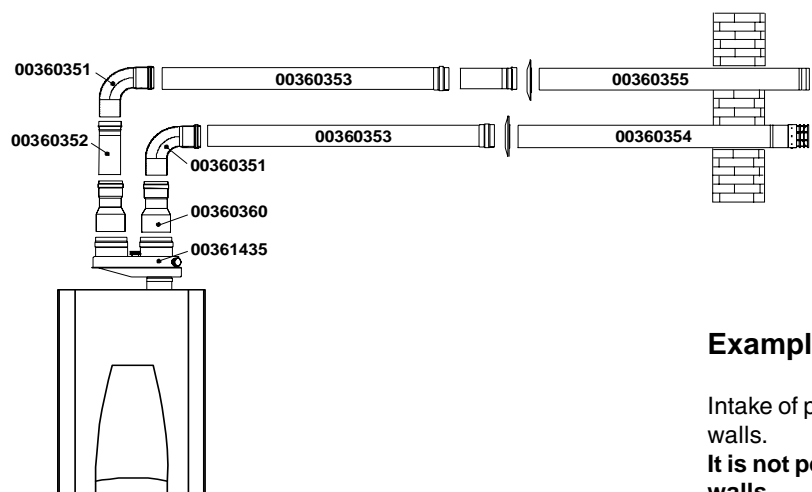

### Example N.2

Intake of primary air and flue outlet from two external perimeter walls.

**It is not permitted to position the two terminals on opposite walls.**

## Instruction for the installer

### 3.12 - ELECTRICAL CONNECTIONS

The appliance's electrical safety is guaranteed only when the same appliance has been correctly earthed in compliance with the regulations in force. The gas and water feeding pipes and the CH system pipes cannot be used as ground plates.

Ensure that the above safety electrical requirements subsist; in case of doubt, ask for a professionally qualified technician to check the appliance's electrical system.

UNICAL refuses responsibility for any damages arising from failure to earth the boiler correctly.

It is necessary that a qualified technician verifies that the electrical system is adequate to the appliance's maximum absorbed power, indicated on the data plate, verifying in particular that the section of the system's cables is suitable to the appliance's maximum absorbed power.

For the appliance's general electrical supply the use of adaptors, multiple sockets and/or extension cords is strictly forbidden.

The use of any power supplied equipment implies the observance of several fundamental rules, such as:

- Do not touch the appliance with any wet part of your body and/or barefooted;
- Do not pull the supply cables;
- Do not expose the boiler to sunlight, rain, etc., unless it is explicitly foreseen;
- Do not permit children or inexperienced people to use the appliance.

### Connection to mains supply 230V

The boiler is provided complete with a 1,5 m long, mains supply cable, with a cross section area of 3x0,75 mm<sup>2</sup>.

The boiler's electrical connections are shown in the section named "WIRING DIAGRAMS" (paragraph 3.13 pages 31 and 32)

A mains supply of 230 V – 50 Hz is required. The wiring to the boiler must be in accordance with the current CEI regulations.



**DANGER!**  
The electrical connections must be carried out only by a qualified engineer. Before carrying out the connections or any other operation on the electrical parts, always switch off and disconnect the electricity supply and ensure yourself that it cannot be accidentally turned on.



Note: It is necessary to fit a double pole switch on the electrical supply line, having a 3 mm contact separation in both poles, in an easy accessible position so as to ensure quick and safe servicing.



The replacement of the supply cable as to be carried out by a qualified authorized UNICAL engineer, using only original spare parts. The non-observance of the above could compromise the appliance's safety.

### Access to the electrical terminal block and external connections



**DANGER!**  
Switch off and disconnect the electricity supply before carrying out any operations on the electrical parts.

- Remove the front panel.
- To gain direct access to the connection areas remove the 4 screws "A" and remove the cover "B".

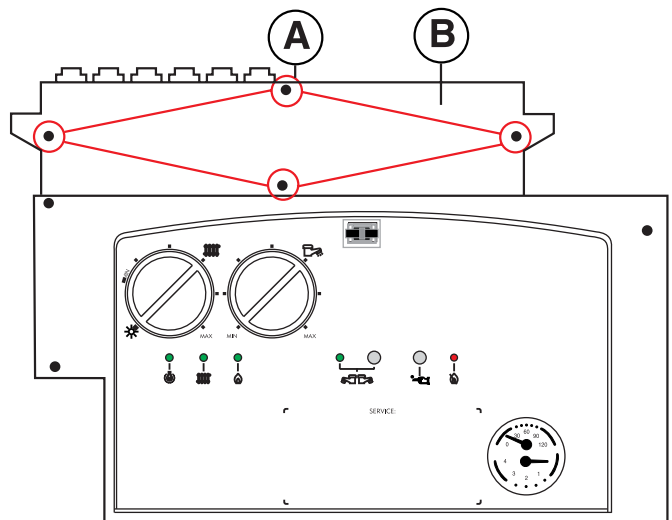

### View of the terminal board after having removed the front cover

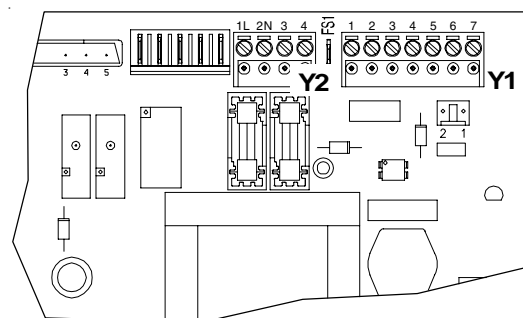

## Outdoor sensor connection (optional)



**DANGER!**  
Switch off and disconnect the electricity supply before carrying out any operations on the electrical parts.

- Remove the 4 screws "A" and remove the cover "B"
- Gain access to the external terminal strip Y1

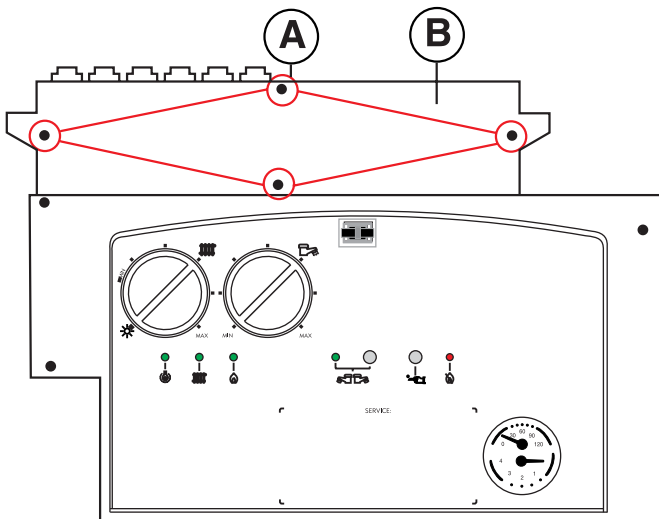

- Connect the outdoor sensor by wiring it onto the terminal strip Y1 to the connection terminals 2 and 3 and wire it to the terminal 1 for their electric shielding.

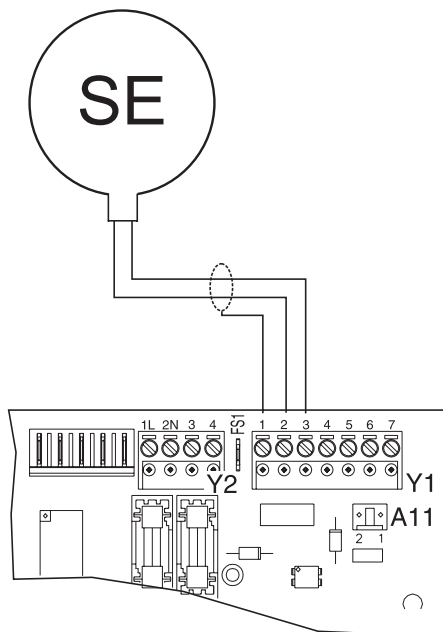

With this solution it is possible to control the flow temperature according to the variations of the outdoor temperature. However, it is necessary to configure the heating curve. The curve can be "drawn" by setting the maximum and minimum flow design temperatures: the first one must be selected on the boiler (via the "C" knob on the control panel – max. setting 80°C), whilst the second is set at 30°C (MINIMUM HEATING TEMPERATURE).

Subsequently we have to make the maximum flow temperature correspond to the minimum external temperature by setting the Otc parameter (outdoor sensor set-point)

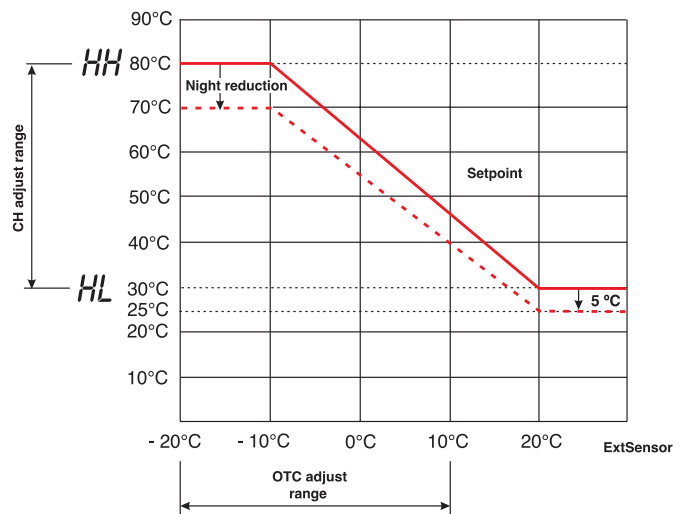

This adjustment must be made via the knob positioned on the rear side of the panel (turn the knob in an anti-clockwise direction between a value from 10 to -19). Obviously this temperature is different from zone to zone and varies in function of the climatic conditions of the installation site (it corresponds to the minimum design temperature). The minimum flow temperature instead (HL) is automatically set by the boiler when the outdoor temperature is +20°C.

Once these parameters have been set the boiler will choose a flow temperature on the heating curve on the basis of the outdoor sensor readout.

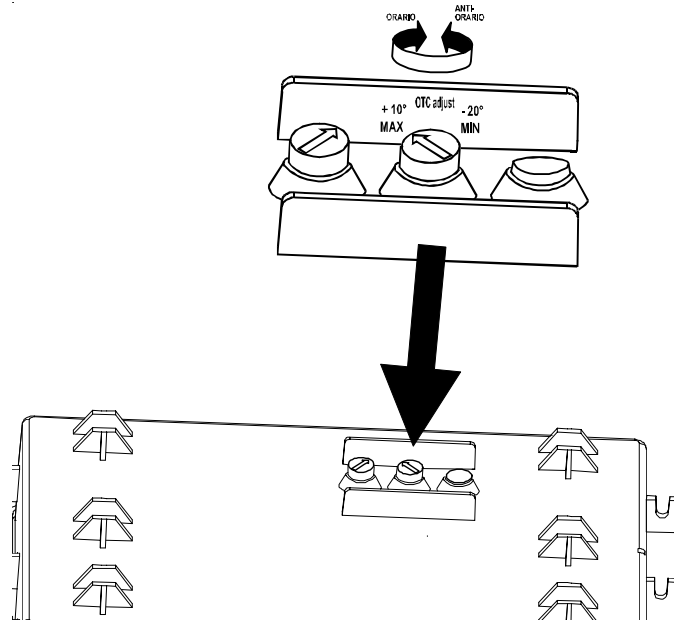

**Note:** This adjustment could be susceptible to subsequent slight changes in function of the outdoor sensor's location.

## Instruction for the installer

### ON-OFF digital room controller connection (optional)



**DANGER!**  
Switch off and disconnect the electricity supply before carrying out any operations on the electrical parts.

- Gain access to the terminal strip Y2
- Remove the existing jumper positioned between the terminals 3-4 and in its place connect the RT cable, making it pass through an extractible grommet available on the control box.

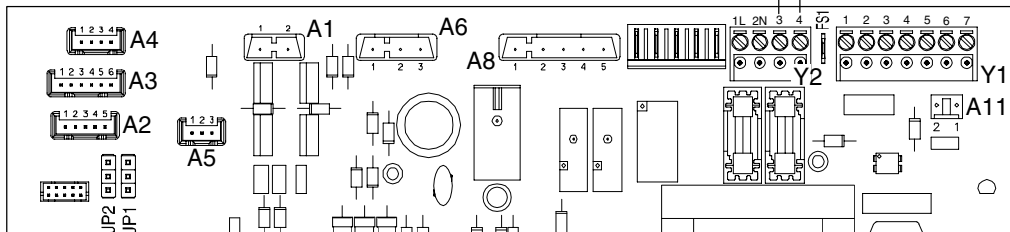
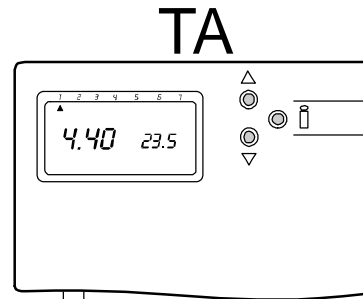

### Modulating RT/OT digital room controller connection (optional)



**WARNING!**  
The modulating room controllers must be supplied by Unical.



**DANGER!**  
Switch off and disconnect the electricity supply before carrying out any operations on the electrical parts.

- Gain access to the terminal strip Y1
- Connect the TA modulating cable to the terminals 4-5 of the terminal strip Y1, making them pass through an extractible grommet available on the control box.
- Remove the jumper positioned between the terminals 3-4 on the terminal strip Y2.

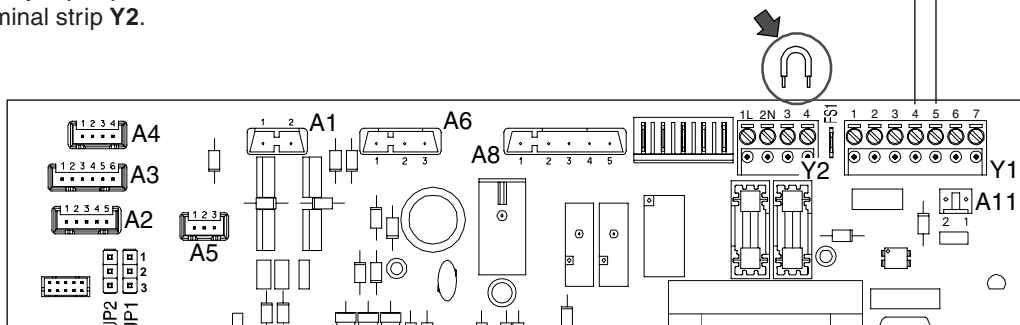
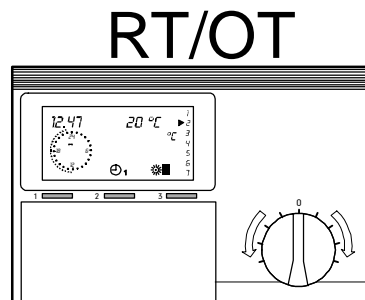

**Layout of the electrical connections for zone control systems**

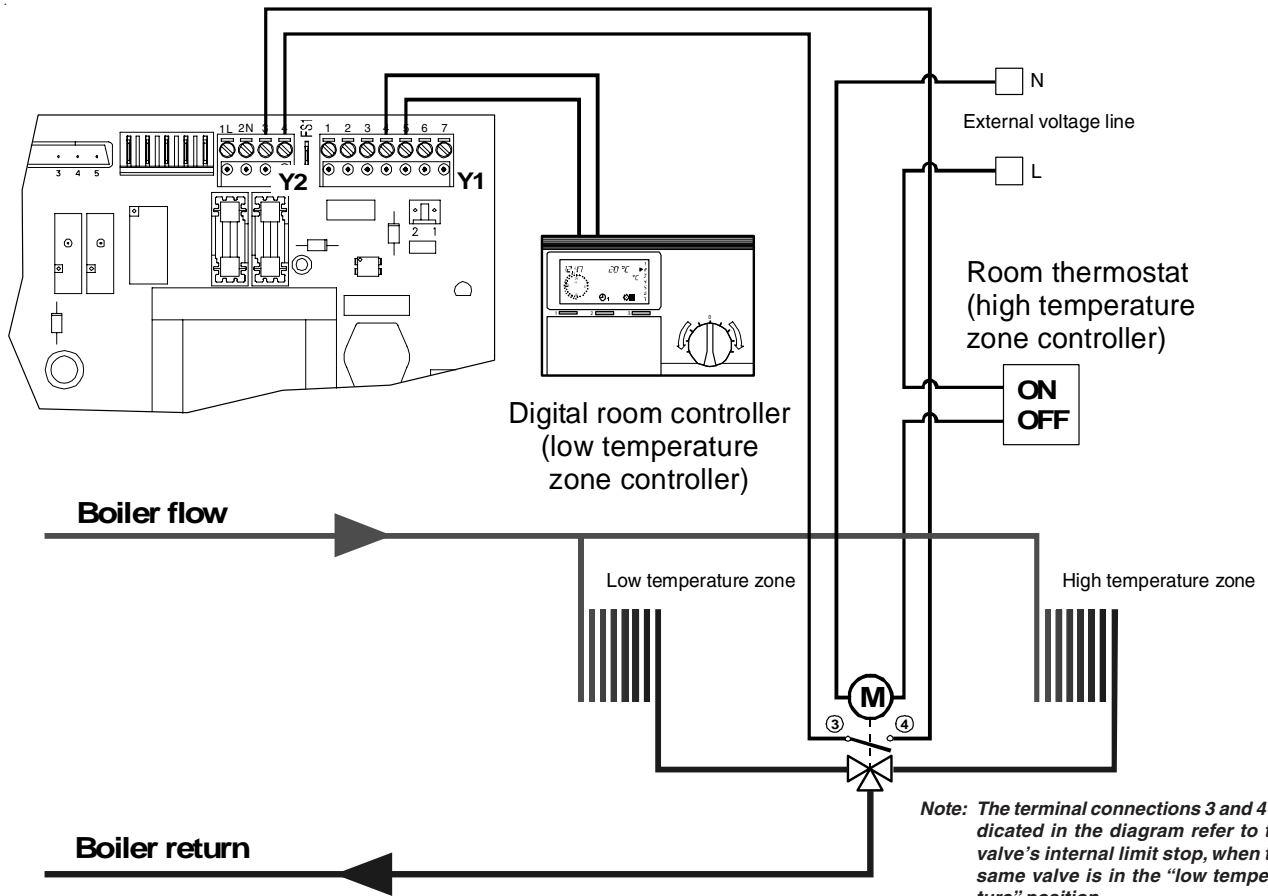

When the thermostat's contact (On-Off) is closed, the 3-way valve opens the high temperature zone and closes the low temperature zone (controlled by the digital room controller "Regolafacile").

With the thermostat's contact (On-Off) open, the 3-way valve deviates towards the low temperature zone (the temperature value can be adjusted with the digital room controller).

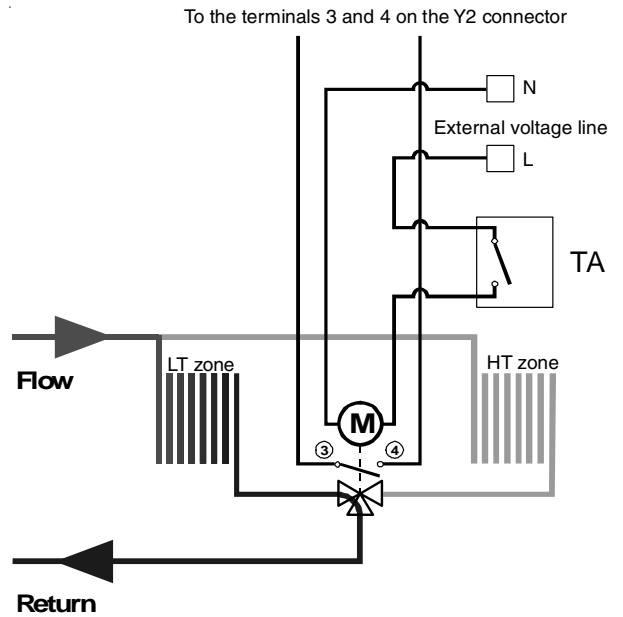
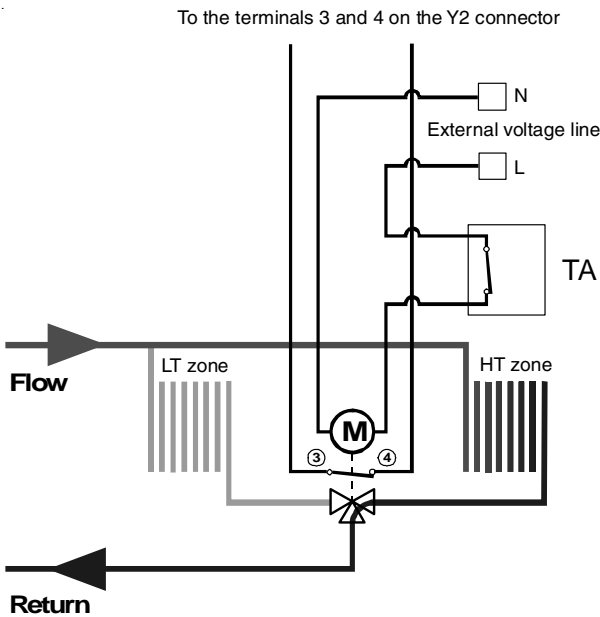

The microswitch on the 3-way valve closes whilst the room thermostat is demanding heat when the diverter valve reaches the "low temperature" position and sends the request to the boiler.

The 3-way valve has to use the limit switch contact in order to simulate this type of request.

# Instruction for the installer

## 3.13 - WIRING DIAGRAMS

### FUNCTIONAL FLOW WIRING DIAGRAM ALKON 24/28/35 C

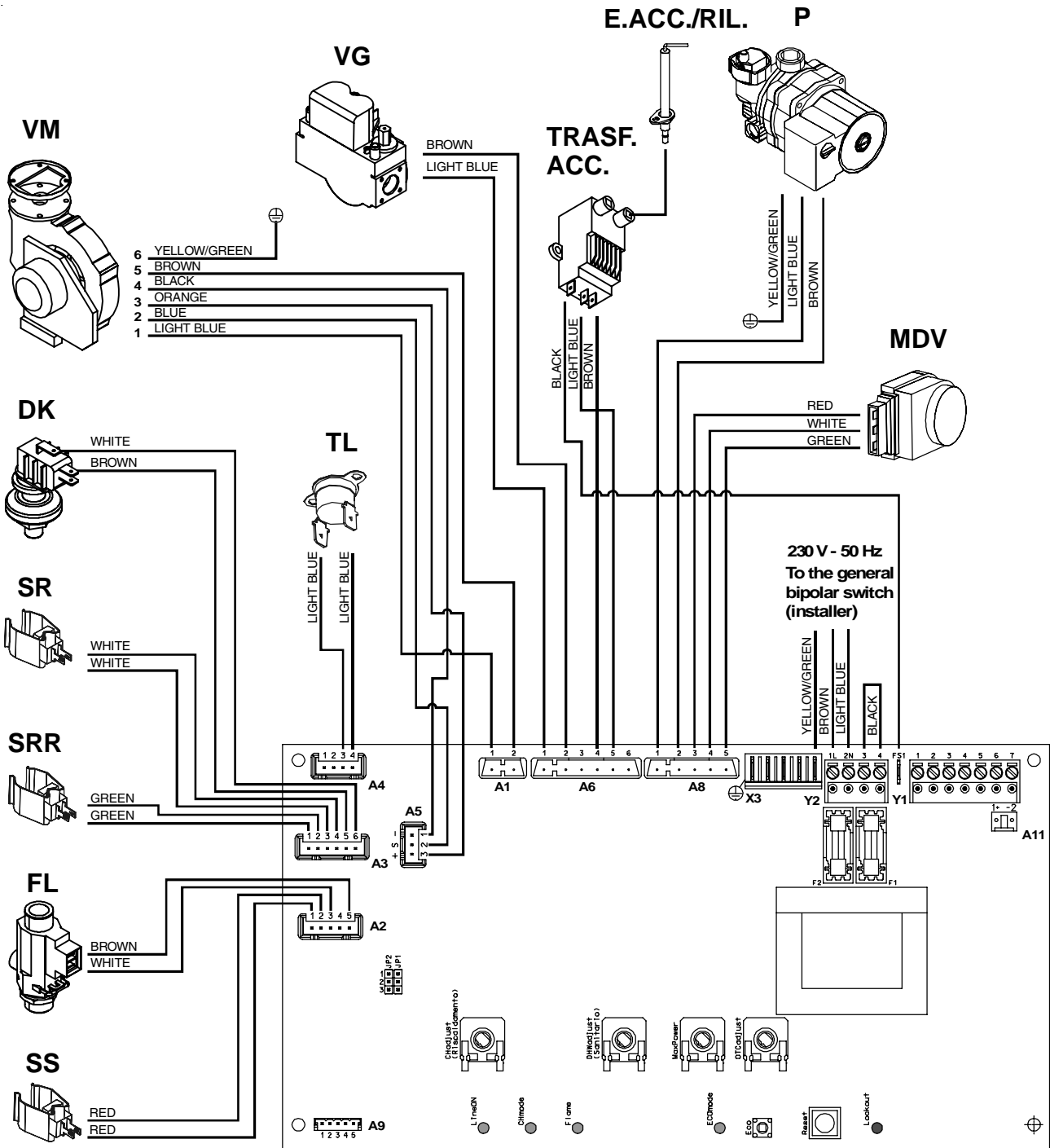

- |            |                                 |    |  |
|------------|---------------------------------|----|--|
| A1...A11   | = Service connectors            | TL | = Limit thermostat   |
| DK         | = Minimum water pressure switch | VG | = Gas valve  |
| E.ACC./RIL | = Ignition/detection electrode  | VM | = Modulating fan   |
| FL         | = Minimum flow switch           | Y1 | = Connector: Outdoor sensor- modulating room thermostat    |
| MVD        | = Diverting valve motor         | Y2 | = Connector: Line voltage - On/Off room thermostat (230 V) |
| P          | = Circulating pump              |    |  |
| SR         | = CH flow sensor                |    |  |
| SRR        | = CH return sensor              |    |  |
| SS         | = DHW sensor                    |    |  |



**FUNCTIONAL FLOW WIRING DIAGRAM ALKON 18/24/28/35 R**

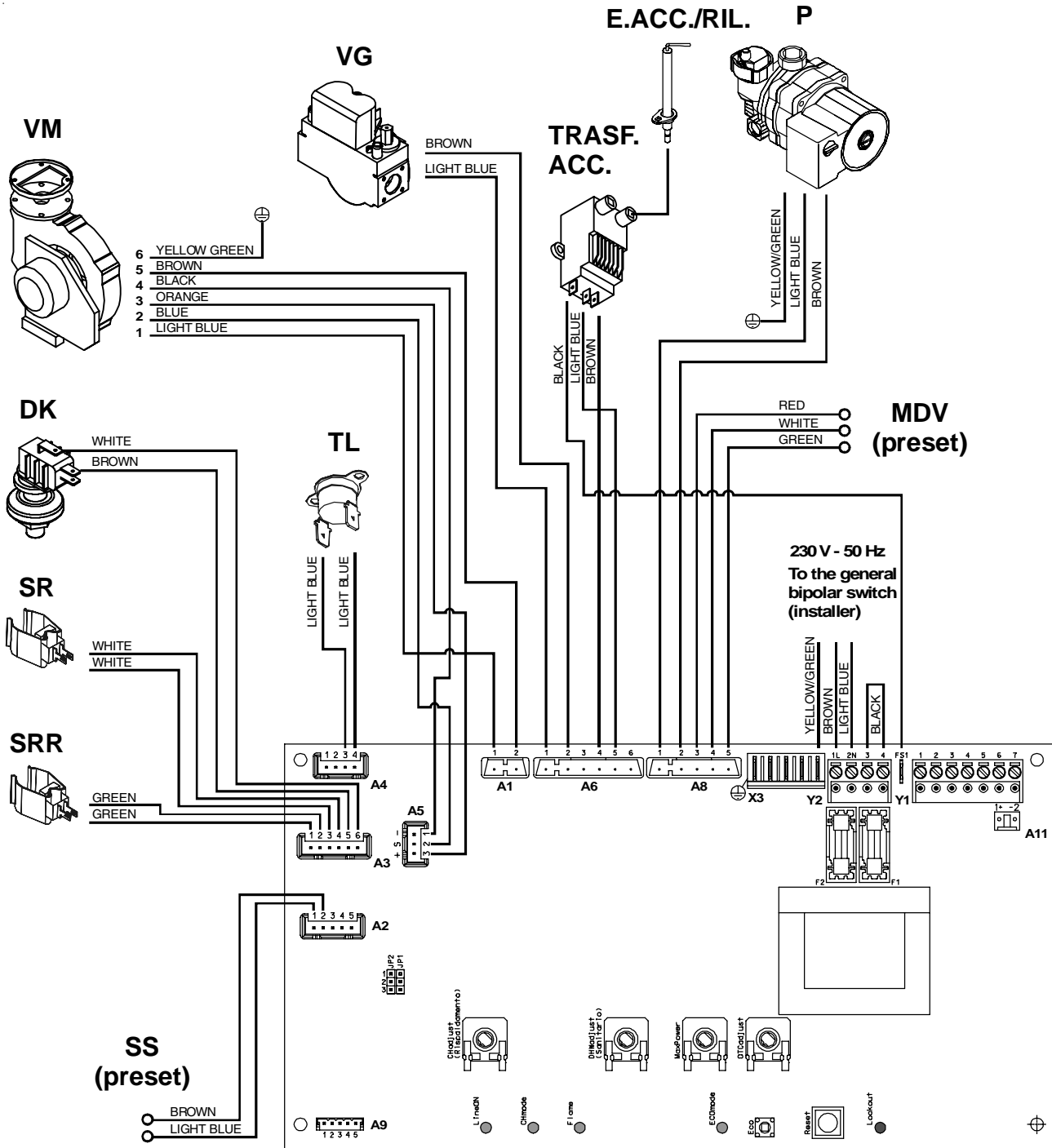

- A1...A11 = Service connectors
- DK = Minimum water pressure switch
- E.ACC./RIL. = Ignition/detection electrode
- P = Circulating pump
- SR = CH flow sensor
- SRR = CH return sensor
- TL = Limit thermostat

- VG = Gas valve
- VM = Modulating fan
- Y1 = Connector: Outdoor sensor- modulating room thermostat
- Y2 = Connector: Line voltage - On/Off room thermostat (230 V)

## Instruction for the installer

### JUMPER LOCATION

The jumpers, fitted on to the modulation board, have the purpose of determining several indispensable functions for correct boiler operation.



**DANGER!**  
Disconnect and switch off and electrical supply before carrying out any operations on the electrical parts.

To gain access to the jumper:

- Remove the front panel
- Undo the 4 screws A and remove the cover B

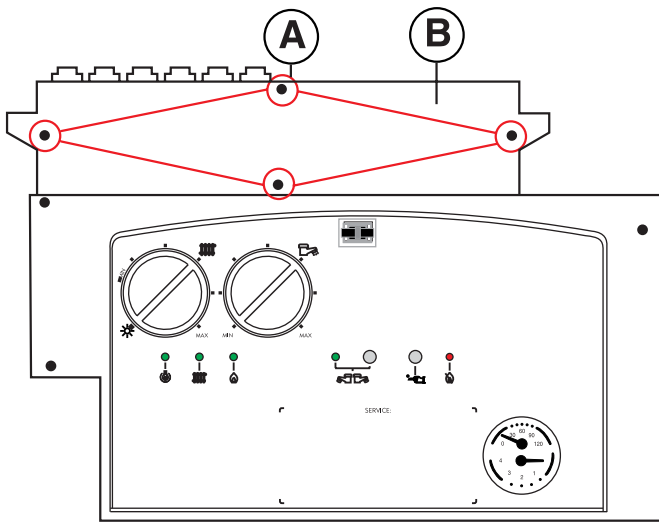

### JP1: NIGHT REDUCTION

The "Night reduction" function is enabled if the jumper is linked between terminals 1 and 2.

The "Night reduction" function is excluded if the jumper is linked between terminals 2 and 3 (factory set configuration).

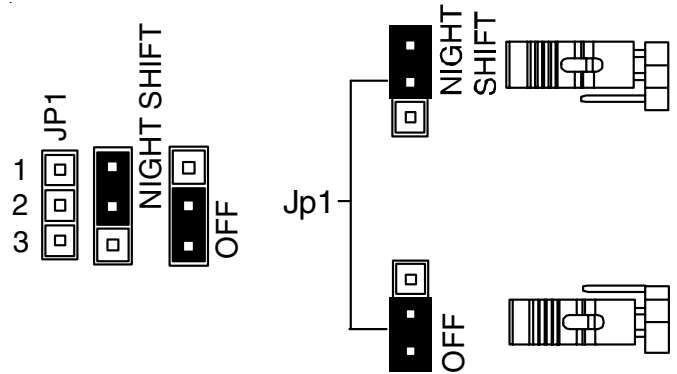

If the jumper is positioned on NS (1-2), the high temperature zone is in permanent demand.

As the high temperature demand has priority on the low temperature demand, the eventual action of the digital remote room controller is completely uninfluential.

The closure of the contact between 3-4 on the Y2 provokes the night reduction mode as illustrated in the graph on page 28.

The opening of the contact between 3-4 on the Y2 restores the selected setpoint temperature and/or renders it independent from the outdoor compensation if an outdoor sensor is fitted.

To disable the central heating demand it is necessary to turn the CH knob to the minimum setting.

The night reduction's default value is 5 (corresponding to 10°C). This value can be changed via the TSP 1 on the digital room controller from 5 (10°C) to 30 (35°C).

### JP2: GAS TYPE

For boilers operating with LPG, the jumper has to be linked between the connectors 1 and 2.

For boilers operating with natural gas the jumper has to be linked between the connectors 2 and 3.

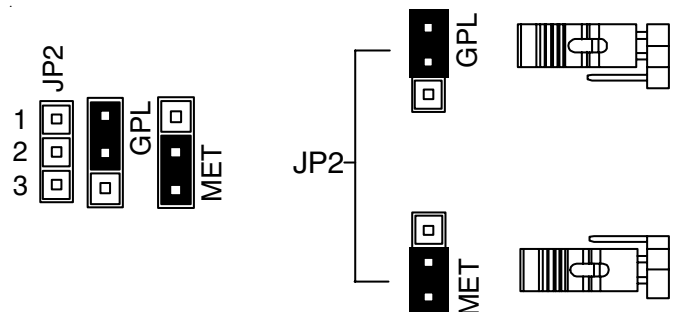

### 3.14 – FILLING THE SYSTEM



#### Warning!

Do not mix the CH system's water with unsuitable anti-freeze products (example: anti-freeze solutions for motor vehicles) or use wrong concentrations of anti-corrosion solutions ! This could cause damage to the washers and could provoke noise during normal boiler operation.

If really necessary, use exclusively specific anti-freeze products suitable for use on aluminium-silicon alloy.

UNICAL refuses all liability for injury to persons, animals or damage to property deriving from not having respected the above mentioned recommendations.

After completing all the system's service connections the circuits may be filled by carefully following out the following phases:

- open the radiator's air vents and check that the automatic air vent in the boiler is working properly.
- gradually open the appropriate filling cock and check that the automatic air vents fitted onto the system are working properly.

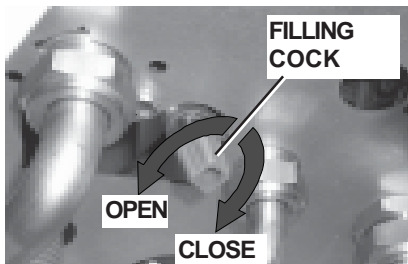

- close the radiator's air vents as soon as water begins to flow out.
- using the pressure gauge check that the pressure reaches the value of 0,8/1 bar.

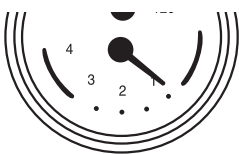

- close the filling cock and then bleed off the air once again through the radiator's air vents.
- check all the connections for soundness.
- after having fired the boiler and the system has reached the correct temperature, stop the pump and repeat the air bleeding operations.
- let the system cool down and, if necessary, re-establish the water pressure to 0,8/1 bar.



#### NOTE:

The minimum low water pressure switch will not give the electrical impulse to fire the burner if the pressure is lower than 0,4 bar. The pressure of the water in the CH system must not be lower than 0,8/1 bar; if this value is lower use the filling cock on the boiler to adjust the pressure.

This operation must be carried out when the system is cold. Use the pressure gauge fitted on the boiler to read the circuit's pressure value.



#### NOTE!

If the boiler has not been fired for a long period the pump could be jammed. Before firing the boiler, it is important to carry out the following un-jamming operation:

- place a cloth underneath the pump
- remove the pump vent plug positioned in the centre of the pump
- using a screwdriver, rotate the shaft in a clockwise direction.

Once this operation has been concluded, screw back the pump vent plug and check that there have been no water leaks.



#### WARNING!

After removing the pump vent plug some slight water leakage could occur. Before replacing the front panel dry all the wet surfaces.

## Instruction for the installer

### 3.15 INITIAL LIGHTING

#### PRELIMINARY CHECKS



The first ignition must be carried out by a qualified technician. Failure to do so could cause injury to persons, animals or damage to property. UNICAL shall not be held liable for any injury and/or damage.

Before lighting the boiler check that:

- the boiler installation has been carried out in accordance with the specific Standards UNI 7129 and 7131 for the gas part and the Standards CEI 64-8 and 64-9 for the electrical part;
- the combustion air inlet and the discharge of the products of combustion occur in the correct way in accordance to the specific Standards in force (UNI 7129/7131);
- the gas supply system is correctly dimensioned for the boiler's output;
- the boiler's electrical supply is 230 V - 50 Hz;
- the system has been filled with water (pressure registered on the gauge 0,8/1 bar with pump not running);
- any of the system's on-off valves are open;
- the mains supply gas corresponds to the one which the boiler has been calibrated for: otherwise convert the boiler to use the available gas (refer to section: "GAS CONVERSION"); this operation must be carried out by a qualified technician in compliance to the regulations in force;
- the gas supply cock is open;
- there are no gas leaks;
- the external mains supply switch is on;
- the boiler system's safety valve is not blocked and that it is connected to the sewage system;
- the condensate drain siphon has been filled with water and that it is connected to the sewage system;



#### **DANGER!**

**Before firing the appliance fill up the siphon through the filling hole and check the correct drainage of the condensate. If the appliance is used with the condensate drain siphon empty this could cause poisoning caused by the leakage of the flue gasses.**

- there are no water leaks;
- all the necessary ventilation conditions and minimum clearance distances are guaranteed for subsequent servicing in case the boiler is sited in a cupboard compartment.

#### LIGHTING AND SHUTTING DOWN PROCEDURES

For lighting and shutting down the boiler refer to the "USER'S INSTRUCTIONS GUIDE".

#### Information to be passed on to the user

**The user must be instructed on the use and operation of his boiler and in particular detail:**

- Hand over to the end user the booklet: "USER'S INSTRUCTIONS GUIDE", as well as all the other literature relative to the appliance and placed in the envelope contained in the packaging. **The user must retain this literature for any future reference.**
- Inform the user of the importance of the air vents and of the flue outlet system, stressing the fact that absolutely no alteration can be made.
- Inform the user regarding the control of the system's water pressure and how to restore it to the correct value.
- Explain and demonstrate to the user the correct function and adjustment of the temperature, thermostats and radiators for the economic use of the system.
- Remind the user that in order to comply to the regulations in force the boiler has to be inspected and serviced regularly as indicated by the manufacturer.
- If the appliance is sold or transferred to another owner or if the present user moves home and leaves the appliance installed, ensure yourself that the manual always follows the appliance so that it can be consulted by the new owner and/or installer.

### 3.16 – BURNER PRESSURE ADJUSTMENT



#### WARNING!

All the instructions indicated below are for the exclusive use of qualified UNICAL service technicians or installers.



All the boilers leave the factory already calibrated and tested. If it is necessary to change the calibration due to gas conversion or adaptation to the mains supply system, the gas valve must be re-calibrated.

**Warning: during this operation do not request any domestic hot water.**

- If necessary correct the value by turning the adjustment screw "A" in a CLOCKWISE direction to decrease the value and in an ANTICLOCKWISE direction in order to increase it.

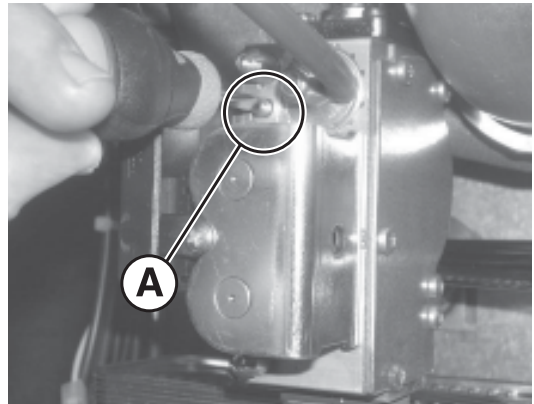

#### A) MAX OUTPUT ADJUSTMENT

- Remove the cap and connect a suitable CO<sub>2</sub> gas analyser to the sampling point in the flue inlet/outlet terminal.

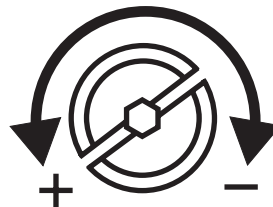
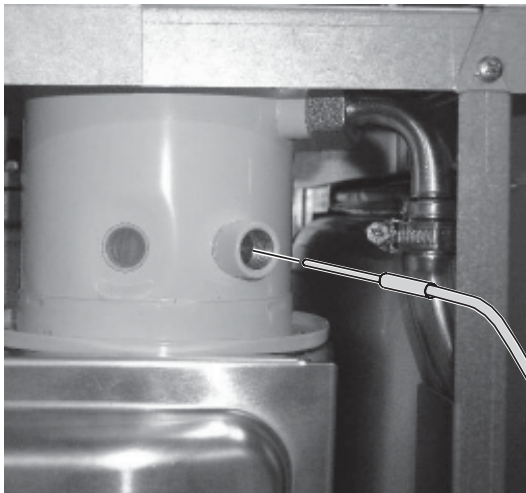

MAXIMUM OUTPUT  
ADJUSTMENT SCREWS

#### B) MIN OUTPUT ADJUSTMENT

- By pressing the Reset "G" key again the boiler will operate at the minimum output (led D and led E = blinking).

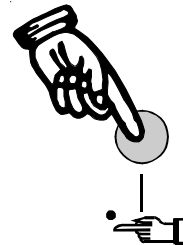
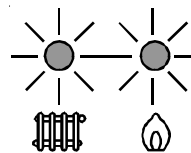

- Press the Reset "G" key for at least 3 seconds. The boiler will operate in the CH mode at the maximum output (led D = blinking and led E = ON).

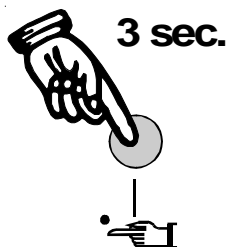
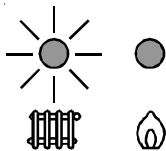

The chimney sweeper mode remains active for 15 minutes.

To disable the **chimney sweeper mode** before this time has run out, press the Reset "G" key for at least 3 seconds.

- Check that the CO<sub>2</sub> values are within the values indicated in the table "Burner pressures".

- Check that the CO<sub>2</sub> values are within the values indicated in the table "Burner pressures".

## Instruction for the installer

- If necessary correct the value by turning the adjustment screw "B" in a CLOCKWISE direction to increase the value and in an ANTICLOCKWISE direction in order to decrease it.

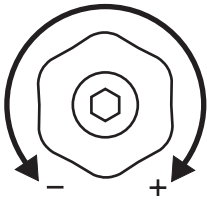
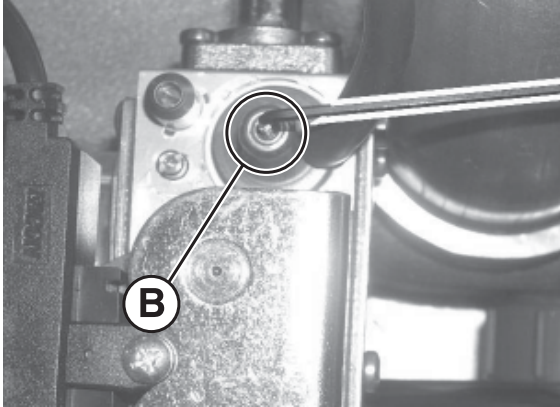

MINIMUM OUTPUT  
ADJUSTMENT SCREWS

## C) COMPLETION OF THE BASIC ADJUSTMENTS

- Check the CO<sub>2</sub> values at the minimum and maximum output.
- If necessary make the required adjustments.



To ensure correct boiler operation the CO<sub>2</sub> values have to be adjusted with extreme care respecting the values indicated in the table.

- Close the sampling test point in the flue inlet/outlet terminal with the appropriate cap C.

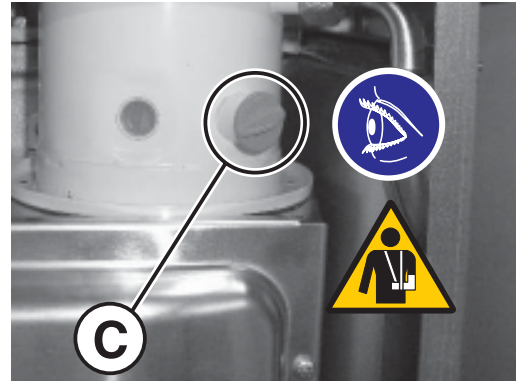

In case of gas valve replacement or difficult ignition:

Screw down completely the maximum adjustment screw "A" in a clockwise direction, than slacken for 7 turns. Check the boiler ignition; if the boiler goes into lockout slacken the screw "A" again of one turn, than retry ignition. If the boiler goes into lockout again, carry out the above indicated operations until the boiler is fired. At this point carry out the burner adjustment as previously indicated.

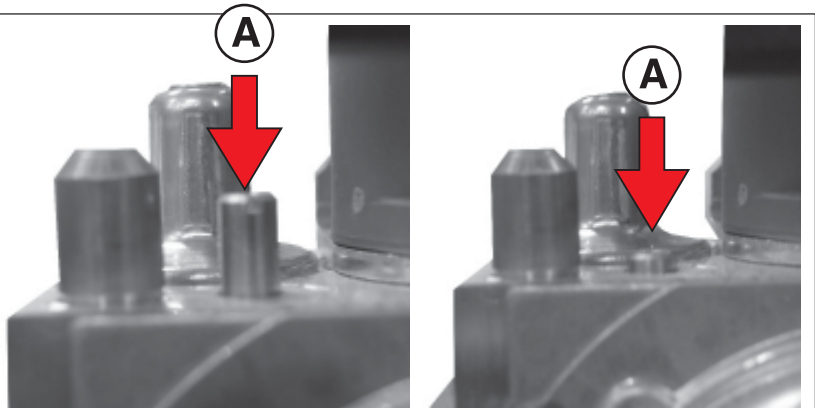

### INJECTORS – PRESSURES

Check the CO<sub>2</sub> levels often, especially at low output

Gas type	Supply pressure (mbar)	Collector Diaphragm (Ø and n. holes )	CO2 levels (%)		Fan speed (rpm)		Mixer injector (Ø mm)	Flue outlet diaphragm (Ø mm)	Min gas consumption	Max gas consumption	Start-up firing rate %
			min	max	min	max					

#### ALKON 18 Burner type “U” see page 44

Nat. gas (G20)	20	8,6 x 6	8,8	9,0	1600	5900	5,6	26	0,36 m³/h	1,80 m³/h	30
Nat. gas (G25)	20	8,6 x 6	8,8	9,0	1600	5900	7,0	26	0,42 m³/h	2,09 m³/h	30
LPG (G31)	50	8,6 x 6	10,2	10,2	1500	5600	5,6	26	0,26 kg/h	1,32 kg/h	30

#### ALKON 18 Burner type “A” see page 44

Nat. gas (G20)	20	8,7 x 4	9,2	9,2	1500	7000	5,6	-	0,36 m³/h	1,80 m³/h	20
Nat. gas (G25)	20	8,7 x 4	9,2	9,2	1500	7000	9,0	-	0,42 m³/h	2,09 m³/h	20
LPG (G31)	50	8,7 x 4	10,1	10,3	1400	7000	5,6	-	0,26 kg/h	1,32 kg/h	40

#### ALKON 24 Burner type “U” see page 44

Nat. gas (G20)	20	8,6 x 8	9,0	9,0	1700	7000	5,6	-	0,45 m³/h	2,52 m³/h	5
Nat. gas (G25)	20	8,6 x 8	9,0	9,0	1700	7000	9,0	-	0,53 m³/h	2,97 m³/h	5
LPG (G31)	50	8,6 x 8	10,2	10,5	1600	7000	5,6	26	0,33 kg/h	1,85 kg/h	5

#### ALKON 24 Burner type “A” see page 44

Nat. gas (G20)	20	8,6 x 9	9,3	9,0	1400	7000	5,6	-	0,45 m³/h	2,52 m³/h	10
Nat. gas (G25)	20	8,6 x 9	9,0	9,0	1400	7000	9,0	-	0,53 m³/h	2,97 m³/h	10
LPG (G31)	50	9,0 x 6	10,2	10,8	1500	7000	5,6	-	0,33 kg/h	1,85 kg/h	20

#### ALKON 28 Burner type “U” see page 44

Nat. gas (G20)	20	9 x 10	8,8	9,0	1500	6100	5,6	34	0,60 m³/h	2,96 m³/h	50
Nat. gas (G25)	20	9 x 10	8,8	9,0	1500	6100	7,0	34	0,69 m³/h	3,44 m³/h	50
LPG (G31)	50	9 x 10	10,6	10,5	1400	5800	5,6	34	0,43 kg/h	2,17 kg/h	5

#### ALKON 28 Burner type “A” see page 44

Nat. gas (G20)	20	-	9,2	9,2	1200	5400	5,6	-	0,60 m³/h	2,96 m³/h	40
Nat. gas (G25)	20	-	9,3	9,2	1200	5400	9,0	-	0,69 m³/h	3,44 m³/h	40
LPG (G31)	37	-	10,0	10,3	1200	5300	5,6	-	0,43 kg/h	2,17 kg/h	40

#### ALKON 35 Burner type “U” see page 44

Nat. gas (G20)	20	-	9,0	9,0	1500	6200	5,6	34	0,74 m³/h	3,70 m³/h	50
Nat. gas (G25)	20	-	9,0	9,0	1500	6200	7,0	34	0,86 m³/h	4,28 m³/h	50
LPG (G31)	50	-	11	11	1400	5800	5,6	34	0,54 kg/h	2,72 kg/h	5

## Instruction for the installer

### 3.17 - VARIATION OF OUTPUT RANGE

It is possible to adjust the maximum input by reducing the fan speed.

With the "Regolafacile" parameter FHCH:  
rpm x 100 ex. 70 = 7000 rpm

For example: with the parameter FHCH settled on 50, the correspondent maximum input will be of 13.5 kW for ALKON 18; 16.5 kW for ALKON 24; 22.5 kW for ALKON 28; 28 kW for ALOKN 35.

#### ALKON 18 R (A)

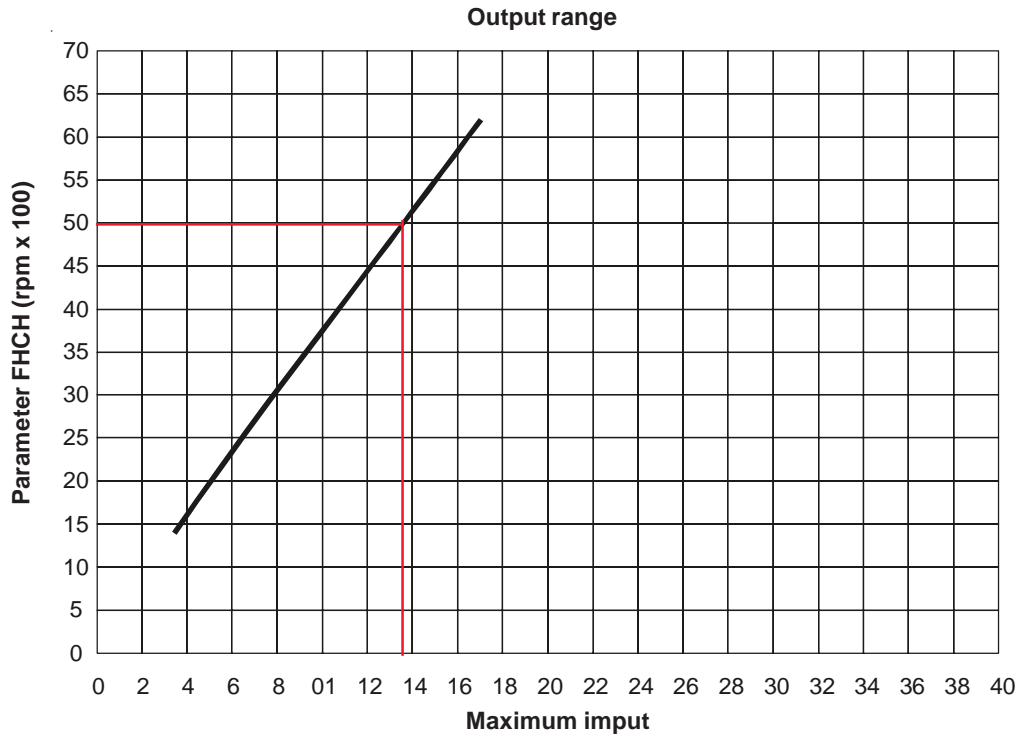

#### ALKON 24 R - C (B)

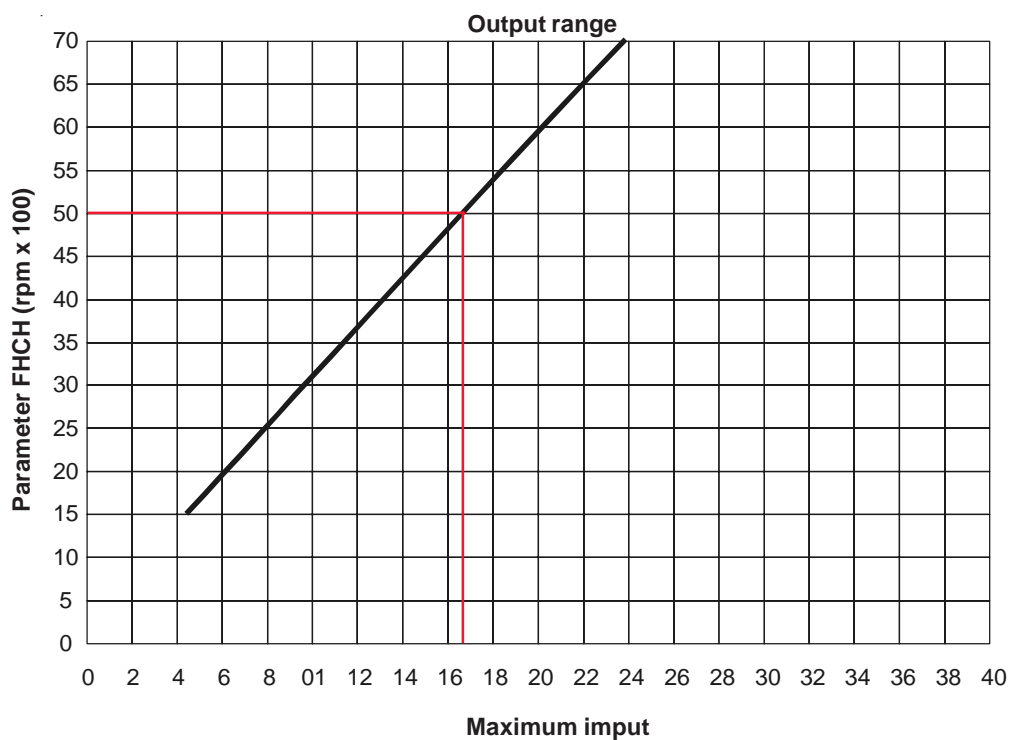



### ALKON 28 R - C (C)

Output range

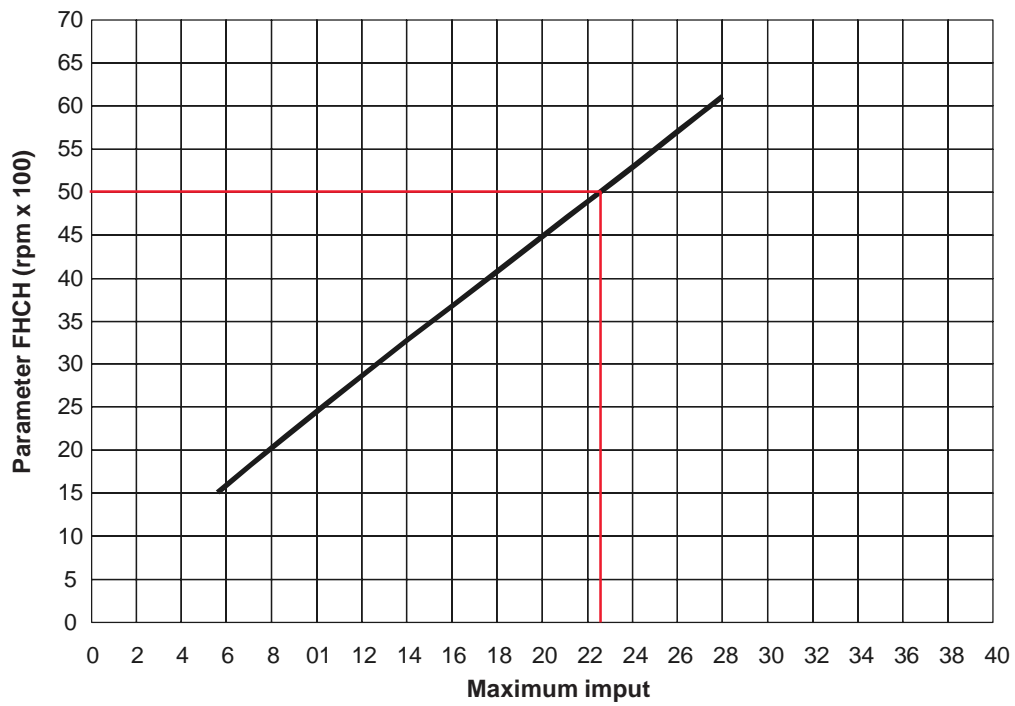

### ALKON 35 R - C (D)

Output range

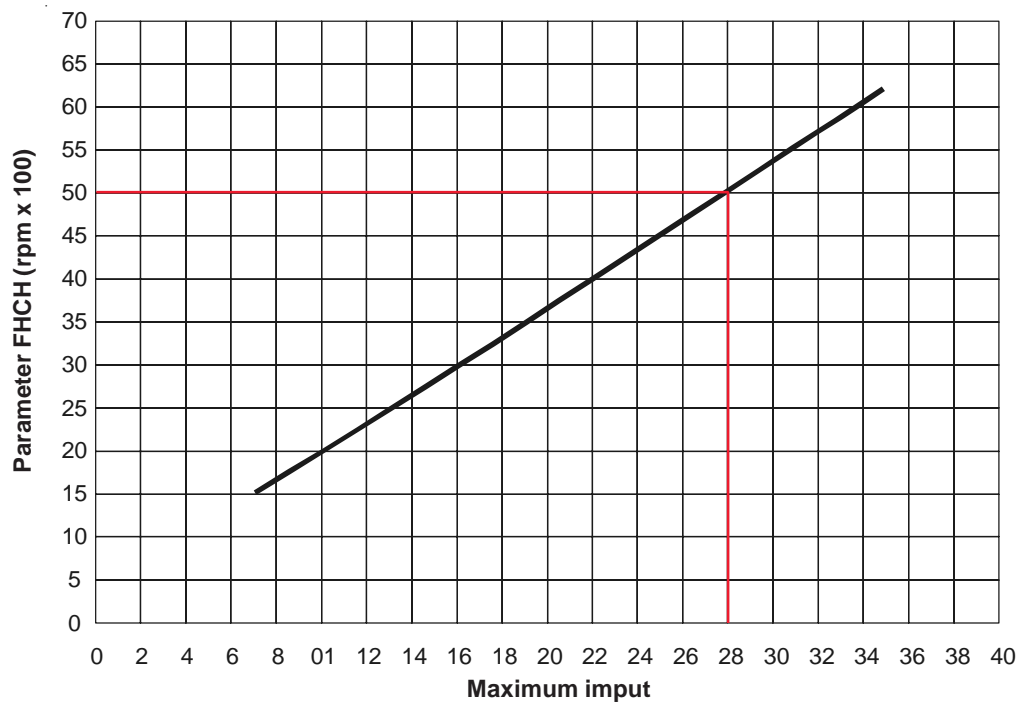

### 4

## INSPECTION AND SERVICING SCHEDULE



To ensure the continued safe and efficient operation of the boiler it is highly recommended that it is checked at regular intervals and serviced when necessary, and that only original spare parts are used. Regular attention will prolong the life of the boiler.



If the boiler is not checked and serviced regularly it could cause material and personal damages.

For this reason UNICAL recommends that a servicing contract should be made with our authorized After Sales Service Assistance Centre.

The boiler must have regular maintenance and cleaning in order to ensure reliable and efficient operation. Regular attention will prolong the life of the boiler.

The frequency of servicing will be determined by the service engineer and will depend on the appliance's state of condition.

### INSTRUCTIONS FOR INSPECTION AND SERVICING



To ensure a long life to all your boiler components and in order not to alter the conditions of the approved product, only original UNICAL spare parts must be used.

Before servicing always carry out the following steps:

- Disconnect the mains electricity supply.
- Separate the appliance from the electrical supply by means of a separating device with an opening contact of at least 3 mm (for example safety devices or power switches) and ensure yourself that it cannot be accidentally reinserted.
- Close the on-off valve fitted upstream of the boiler.
- If necessary, and in function of the type of work to be carried out, close any on-off valves fitted on the CH flow and return pipes, as well as the cold water inlet valve.
- Remove the appliance's front panel.

After having carried out all the necessary maintenance work always follow these steps:

- Open the CH flow and return valves as well as the cold inlet valve (if previously closed),
- Purge and, if necessary, proceed with restoring the heating system's pressure until a pressure of 0,8/1 bar is reached.
- Open the on-off gas cock.
- Reconnect the appliance to the electrical supply and switch on the mains electrical supply.
- Test for gas soundness, on the gas side and on the water side.
- Replace the appliance's front panel.

**TABLE OF RESISTANCE VALUES AS A FUNCTION OF THE HEATING SENSOR (SR) AND DHW (SS) TEMPERATURE SENSORS**

T°C	0	1	2	3	4	5	6	7	8	9
0	32755	31137	29607	28161	26795	25502	24278	23121	22025	20987
10	20003	19072	18189	17351	16557	15803	15088	14410	13765	13153
20	12571	12019	11493	10994	10519	10067	9636	9227	8837	8466
30	8112	7775	7454	7147	6855	6577	6311	6057	5815	5584
40	5363	5152	4951	4758	4574	4398	4230	4069	3915	3768
50	3627	3491	3362	3238	3119	3006	2897	2792	2692	2596
60	2504	2415	2330	2249	2171	2096	2023	1954	1888	1824
70	1762	1703	1646	1592	1539	1488	1440	1393	1348	1304
80	1263	1222	1183	1146	1110	1075	1042	1010	979	949
90	920	892	865	839	814	790	766	744	722	701

Relationship between the temperature (°C) and the nominal resistance (Ohm) of the CH sensor and the DHW sensors.

Example: At 25°C, the nominal resistance is 10067 Ohm  
At 90°C, the nominal resistance is 920 Ohm

## Inspections and servicing schedule

Recommended servicing operations	Check annually	Check every 2 years
Examine all water seal components for soundness	●	
Test for gas soundness		●
Check the water and gas safety devices	●	
Clean the combustion circuit heat exchanger/body	●	
Clean the burner and check the ignition efficiency	●	
Clean the fan	●	
Check efficiency of fan's operation		●
Check the gas flow rate and eventual gas adjustment	●	
Check the flue outlet system	●	
Check the hydraulic system		●
Combustion analysis		●
Clean the DHW heat exchanger (only on the "C" model)		●
Control the efficiency of the electrical and electronic components		●
Clean the condensate drain siphon and check that it is discharging correctly	●	



### DANGER!

If, during inspection visits and/or servicing of the appliance, the heat exchanger/boiler body has to be dismantled, the sealing gasket **MUST** be replaced each time.

When reassembling the distributor, ensure that the nuts are re-screwed in sequence, using a suitable dynamometric spanner calibrated to 10 Nm (1 kgm).

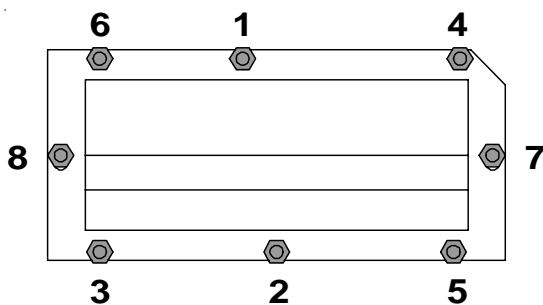

## Inspections and servicing schedule



IDENTIFICATION TYPE OF BURNER ADOPTED  
On the technical data plate, at the voice (5) **S.N°** (page 5)

08**A**..... 08**U**.....



the third figure identifies the type of burner during regulation  
stick to the values indicated in the table on page 35.

### ALKON - Burner type "A"

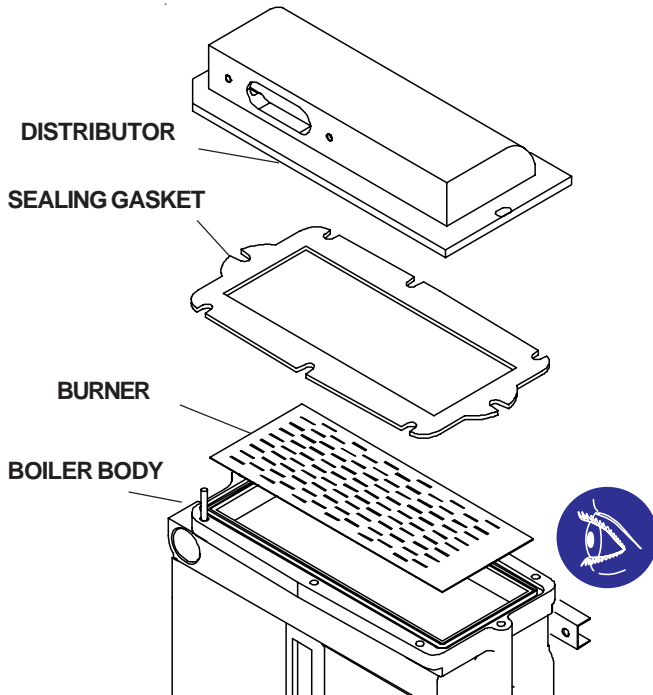

### ALKON - Burner type "U"

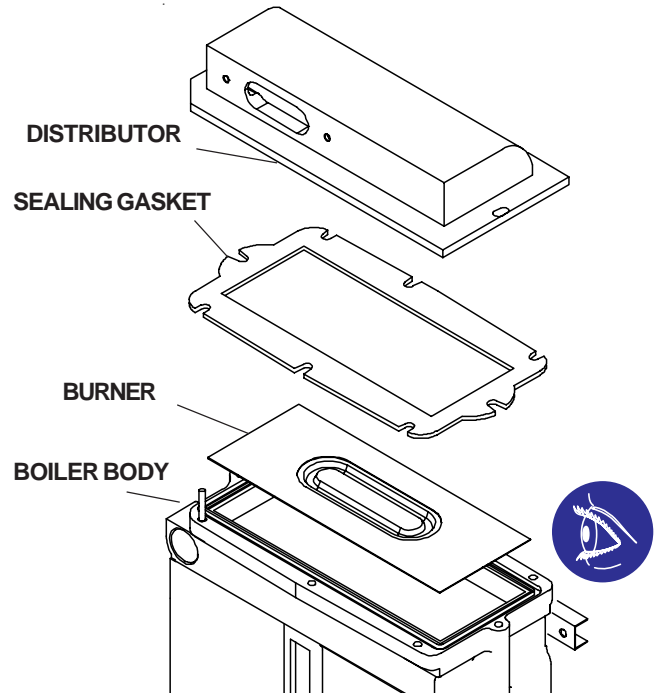

# 5 FAULT CODES

The boiler is fitted with an integrated diagnostic readout which, in case of malfunction, consents the immediate individuation of the type of fault, thanks to the combination of several LEDs (flashing/on/off) on the control panel display. Below are listed the types of recognized fault codes.

These codes are divided into the following 3 groups:  
**1<sup>st</sup> group:** they are signalled but boiler operation is normal.  
**2<sup>nd</sup> group:** the burner is automatically switched off.  
**3<sup>rd</sup> group:** the burner is automatically switched off. To reset the boiler it is necessary to disconnect the boiler from the mains supply.



Led On and flashing



Led On and constantly illuminated



Led Off

## 1° GROUP

### Service parameters

Description:  
Alteration of the service parameters caused by electromagnetic disturbances.

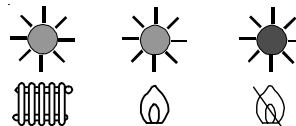

CODE DISPLAYED ON THE DIGITAL ROOM CONTROLLER

**03**

### Return temperature sensor

Description:  
Interruption or short circuit of the return sensor.

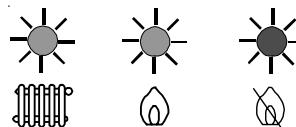

CODE DISPLAYED ON THE DIGITAL ROOM CONTROLLER

**16**

### Insufficient water circulation

Description:  
It is detected when the temperature difference between the flow temperature sensor and the return temperature sensor is > 35°C.  
It is annulled when the temperature difference is < 25°C.

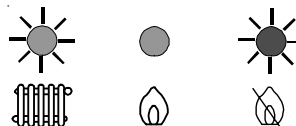

CODE DISPLAYED ON THE DIGITAL ROOM CONTROLLER

**21**

## 2° GROUP

### No flame detection

Description:  
No flame detection during ignition phase: faulty ionisation electrode.  
Refire the boiler by pressing the reset button.

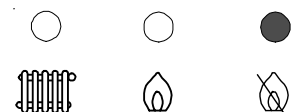

CODE DISPLAYED ON THE DIGITAL ROOM CONTROLLER

**0**

### Fan speed adjustment error

Description:  
The fan does not reach the requested speed.

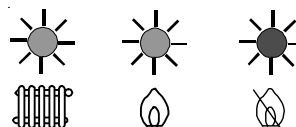

CODE DISPLAYED ON THE DIGITAL ROOM CONTROLLER

**04**

### Overheat heat exchanger

Description:  
It is activated when the flow temperature detected by the sensor in the DHW mode is > 89°C (>92°C in CH mode).  
The code is annulled when the temperature detected by the sensor in DHW mode is <75°C (<80°C in CH mode).

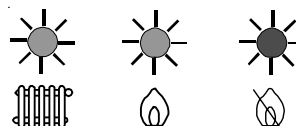

CODE DISPLAYED ON THE DIGITAL ROOM CONTROLLER

**06**

## Codes fault

### Lack of water

Description:

Insufficient water pressure and subsequent intervention of the minimum water pressure switch.

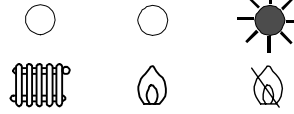

CODE DISPLAYED ON THE DIGITAL ROOM CONTROLLER

**08**

### Frost

Description:

The heat exchanger is frozen. If the heating sensor detects a temperature below 2°C burner ignition remains blocked until the sensor detects a temperature above 5°C.

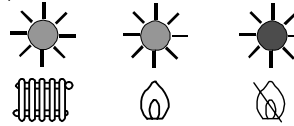

CODE DISPLAYED ON THE DIGITAL ROOM CONTROLLER

**09**

### High Limit thermostat

Description:

A temperature of >100 is detected at the heat exchanger.

The boiler can be refired by pressing the reset key (if the limit thermostat is closed)

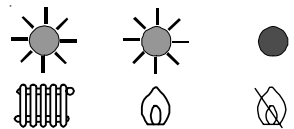

CODE DISPLAYED ON THE DIGITAL ROOM CONTROLLER

**10**

### Factory parameters

Description:

Alteration of the factory parameters caused by electromagnetic disturbances.

Restore the parameters via the remote control.

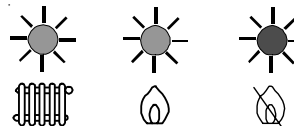

CODE DISPLAYED ON THE DIGITAL ROOM CONTROLLER

**11**

### CH temperature sensor

Description:

Interruption or short circuit of the CH sensor.

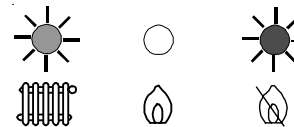

CODE DISPLAYED ON THE DIGITAL ROOM CONTROLLER

**13**

### DHW temperature sensor

Description:

Interruption or short circuit of the DHW sensor.

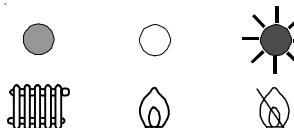

CODE DISPLAYED ON THE DIGITAL ROOM CONTROLLER

**14**

## 3° GRUPPO

### Internal fault

Description:

Internal fault within the modulation board.

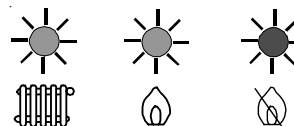

CODE DISPLAYED ON THE DIGITAL ROOM CONTROLLER

**12**

### Incorrect flame detection

Description:

Flame detection with burner Off.

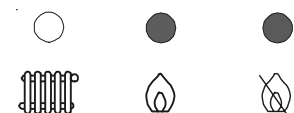

CODE DISPLAYED ON THE DIGITAL ROOM CONTROLLER

**19**

(Directives 90/396/CEE « Appareils à gaz » et 92/42/CEE « Rendement des chaudières »)  
(« Gas appliances » 90/396/EEC and 92/42/EEC « Boilers efficiency » Directives)

**Numéro : 1312BQ4306** (rév. 7)

**CERTIGAZ**, après examen et vérifications, certifie que l'appareil :

**CERTIGAZ**, after examination and verifications, certifies that the appliance :

- **Fabriqué par :**  
*Manufactured by :* **UNICAL AG SpA**  
**Via Roma, 123**  
**I-46033 CASTEL D'ARIO (MN)**
- **Marque commerciale et modèle(s) :**  
*Trade mark and model(s) :* **UNICAL – ENEL.SI**  
  - ALKON 70 - ALKON 50 – ALKON MASTER 50
  - ALKON 18 R – ALKON 24 R
  - ALKON 24 C – ALKON 28 C
  - ALKON 35 R – ALKON 35 C
  - ALKON 35S R – ALKON 35S C
  - EK 280
  - ALKON CARGO 35 – ALKON CLIPPER 28
- **Genre de l'appareil :**  
*Kind of the appliance :* **CHAUDIERE A CONDENSATION**  
**CONDENSING BOILER**  
(Types B23, C13, C33, C43, C53, C63, C83, C13x, C33x, C43x, C63x, C83x)
- **Désignation du type :**  
*Type designation :* **ALKON 50**

Pays de destination <i>Destination countries</i>	Pressions (mbar) <i>Pressures (mbar)</i>	Catégories <i>Categories</i>
FR	20/25 ; 37	I12Esi3P
ES-GB-IE-IT-PT-GR-SE-NO	20 ; 30/ 37	I12H3P
DE	20 ; 50	I12ELL3P
HU	25 ; 50	I12HS3P
AT-CH-TR-HR-CZ-SK-SI	20 ; 50	I12H3P
LV-EE-LT	20	I2E
BE	20/25	I2E(s)B
BE	37	I3P
NL	25 ; 30-50	I12L3P
BG-CN-RU-RO	20	I2H
LU	20 ; 50	I12E3P
PL	20;13;378	I12ELs3P

est conforme aux exigences essentielles des directives « Appareils à gaz » 90/396/CEE et « Rendement des chaudières » 92/42/CEE  
is in conformity with essential requirements of 90/396/EEC « Gas appliances » and 92/42/EEC « Boiler efficiency » directives.

**CERTIGAZ**  
Le Directeur Général

Paris le : 30/09/2008

  
**Yannick ONFROY**  
Rév. 7 : 1312BQ4306 du 2005/05/04

**Unical**AG S.P.A.

46033 casteldario - mantova - italia - tel. 0376/57001 (r.a.) - fax 0376/660556  
[www.unical.ag](http://www.unical.ag) - [info@unical-ag.com](mailto:info@unical-ag.com)

The Unical declines every responsibility for the possible inaccuracies if owed to errors of transcript or press. Also reserves the right to bring those changes that it will hold necessary to its own products or profits, without jeopardizing its essential characteristics.

